

GE

Measurement & Control Solutions

Humidity

RH-Plus MR2350 & MR2350-K

Installation and Operation Manual



imagination at work

63005129 Rev. F
September 2010

GE

Measurement & Control Solutions

RH-Plus MR2350 & MR2350-K

General Eastern Relative Humidity Analyzers

Installation and Operation Manual

63005129 Rev. F
September 2010



www.gesensinginspection.com

©2010 General Electric Company. All rights reserved.
Technical content subject to change without notice.

Chapter 1. Features

1.1 Introduction	1
1.2 Available Versions	2
1.3 Unpacking and Inspection	2
1.4 Theory of Operation	4
1.5 Equipment Drawings	6

Chapter 2. Installation

2.1 Mounting the Probe	9
2.1.0aProbe Mounting Hardware	10
2.2 Opening the Wall-Mount Enclosure.	11
2.3 Mounting the Wall-Mount Enclosure.	12
2.4 Mounting the Panel-Mount Enclosure.	13
2.5 Wiring.	13
2.6 Connecting the Probe.	15
2.6.1 Connecting the Power.	17
2.6.1aAC Supply.	17
2.6.1bDC Supply.	18
2.6.2 Connecting Outputs	19
2.6.2aRelays	19
2.6.2bCurrent Outputs.	19
2.6.2cVoltage Outputs	20
2.6.3 Auxiliary Input Signals.	20
2.6.3a4 to 20mA Loop-Powered Device	20
2.6.3bActive 4 to 20mA Device	21
2.7 Connecting RS-485	22
2.7.1 Components Required	22
2.7.2 Connections	22

Chapter 3. Programming and Operation

3.1 Introduction	23
3.2 Applying Power	23
3.3 Standard Configuration	23
3.4 Controls	24
3.5 The LCD Display	25
3.6 The Programming Matrix	26
3.6.1 Moving Through the Matrix	26
3.6.2 Entering Data	26
3.6.3 “Display Only” Cells	27
3.6.4 Function Guide	28
3.6.5 Accessing the Matrix	28
3.6.6 Locking the Matrix	31
3.6.7 Unlocking the Matrix	31
3.6.8 Matrix Field Details	32
3.7 Analog Output Setup	38
3.8 Relay Setup	40

Chapter 4. Calibration

4.1 Introduction	45
4.2 Calibration Procedure	46

Chapter 5. Troubleshooting and Maintenance

5.1 General Problems	49
5.1.1 Invalid Loop Current	49
5.1.1a If the Unit of Measure is RH (%):	49
5.1.1b If the Unit of Measure is Dewpoint:	49
5.1.2 Slow Response Time	50
5.2 Error Codes	50
5.2.1 Notes	52
5.2.2 Correcting Problems	52
5.3 Signal Test	53
5.4 Probe Replacement	54

Appendix A. Specifications

A.1 MR2350/MR2350-K Analyzer 55

 A.1.1 Electronics: 55

 A.1.2 Standard Inputs: 55

 A.1.3 Optional Input: 55

 A.1.4 Moisture Probe: 55

 A.1.5 User Interface: 55

 A.1.6 Display: 55

 A.1.7 European Compliance: 55

 A.1.8 Units of Measure 56

 A.1.8aMoisture: 56

 A.1.8bTemperature: 56

- A.1.8c Pressure: 56
- A.1.9 Analog Outputs: 56
- A.1.10 Digital Outputs: 56
- A.1.11 Serial Output: 56
- A.1.12 Program: 56
- A.1.13 Data: 57
- A.1.14 Cable Entry: 57
- A.1.15 Operational/Storage Temperature: 57
- A.1.16 Supply Power: 57
- A.1.17 Power Consumption: 57
- A.1.18 Enclosures: 57
- A.1.19 Weight: 57
- A.2 Panel Mount Enclosure 58
 - A.2.1 Material: 58
 - A.2.2 Dimensions: 58
 - A.2.3 Depth: 58
 - A.2.4 Panel cutout: 58
 - A.2.5 Wiring: 58
 - A.2.6 Mounting: 58
 - A.2.7 Front panel surface: 58
- A.3 MDR3 Probe 59
 - A.3.1 Sensing element: 59
 - A.3.2 RH range: 59
 - A.3.3 RH accuracy: 59
 - A.3.4 DP range: 59
 - A.3.5 DP accuracy: 59
 - A.3.6 Standard Operating Temperature: 59
 - A.3.7 Temperature Accuracy: 59
 - A.3.8 Maximum Operating Pressure: 59
 - A.3.9 Signal Transmission: 59
 - A.3.10 Probe Cable Connector: 59
 - A.3.11 Sensor Electronics: 60
 - A.3.12 Probe Tube: 60

A.3.13 Standard Probe Mounting:	60
A.3.14 Sensor Guard:	60
A.3.15 Weight:	60
A.3.16 Approval:	60
A.4 MDR3-N(-K) Probe	61
A.4.1 Sensing Element:	61
A.4.2 RH Range:	61
A.4.3 RH Accuracy:	61
A.4.4 Repeatability:	61
A.4.5 Hysteresis:	61
A.4.6 Dewpoint Range:	61
A.4.7 Dewpoint Accuracy:	61
A.4.8 Operating Temperature:	61
A.4.9 Temperature Accuracy:	61
A.4.10 Maximum Operating Pressure:	61
A.4.11 Sensor Electronics:	62
A.4.12 Radiation Resistance	62
A.4.13 Signal Transmission:	62
A.4.14 Standard Cable Length MDR3-K:	62
A.4.15 Standard Cable Length MDR3-N:	62
A.4.16 Probe Tube MDR3-N:	62
A.4.17 Probe Tube MDR3-K:	62
A.4.18 Location of Probe Electronics (MDR3-N):	62
A.4.19 Location of Probe Electronics (MDR3-K):	62
A.4.20 Sensor Guard:	63
A.4.21 Weight:	63
A.4.22 Approvals:	63
Appendix B. Channel 1 Auxiliary Input Setup	
B.1 Wiring	65
B.2 Configuration	66

Information Paragraphs

- *Note paragraphs provide information that provides a deeper understanding of the situation, but is not essential to the proper completion of the instructions.*
- *Important paragraphs provide information that emphasizes instructions that are essential to proper setup of the equipment. Failure to follow these instructions carefully may cause unreliable performance.*
- **Caution!** paragraphs provide information that alerts the operator to a hazardous situation that can cause damage to property or equipment.
- **Warning!** paragraphs provide information that alerts the operator to a hazardous situation that can cause injury to personnel. Cautionary information is also included, when applicable.

Safety Issues

WARNING! It is the responsibility of the user to make sure all local, county, state and national codes, regulations, rules and laws related to safety and safe operating conditions are met for each installation.

Auxiliary Equipment

Local Safety Standards

The user must make sure that he operates all auxiliary equipment in accordance with local codes, standards, regulations, or laws applicable to safety.

Working Area

WARNING! Auxiliary equipment may have both manual and automatic modes of operation. As equipment can move suddenly and without warning, do not enter the work cell of this equipment during automatic operation, and do not enter the work envelope of this equipment during manual operation. If you do, serious injury can result.

WARNING! Make sure that power to the auxiliary equipment is turned OFF and locked out before you perform maintenance procedures on the equipment.

Qualification of Personnel

Make sure that all personnel have manufacturer-approved training applicable to the auxiliary equipment.

Personal Safety Equipment

Make sure that operators and maintenance personnel have all safety equipment applicable to the auxiliary equipment. Examples include safety glasses, protective headgear, safety shoes, etc.

Unauthorized Operation

Make sure that unauthorized personnel cannot gain access to the operation of the equipment.

Environmental Compliance

Waste Electrical and Electronic Equipment (WEEE) Directive

GE Measurement & Control Solutions is an active participant in Europe's *Waste Electrical and Electronic Equipment* (WEEE) take-back initiative, directive 2002/96/EC.

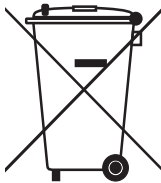

The equipment that you bought has required the extraction and use of natural resources for its production. It may contain hazardous substances that could impact health and the environment.

In order to avoid the dissemination of those substances in our environment and to diminish the pressure on the natural resources, we encourage you to use the appropriate take-back systems. Those systems will reuse or recycle most of the materials of your end life equipment in a sound way.

The crossed-out wheeled bin symbol invites you to use those systems.

If you need more information on the collection, reuse and recycling systems, please contact your local or regional waste administration.

Visit <http://www.gesensing.com/environment/weee.htm> for take-back instructions and more information about this initiative.

Chapter 1. Features

1.1 Introduction

RH-Plus MR2350: The RH-Plus MR2350 is a moisture analyzer designed to operate with the GE MDR3 relative humidity probe. The unit offers an optional input that can be used for pressure compensation, an external temperature probe, or any other sensor. This input can be configured to accept 0 to 5 VDC or 0/4 to 20 mA. The standard product comes with one current output (0–20 mA or 4–20 mA), a system alarm relay, and three adjustable relays all with single-pole double-throw contacts, selectable fail-safe mode, and adjustable hysteresis. One or two additional current outputs are available as options. A display and push buttons form the user interface for data display, selection of units, ranges, setpoints, and special functions.

RH-Plus MR2350-K: The RH-Plus MR2350-K is a moisture analyzer system designed to operate with the GE Sensing MDR3-N(-K) relative humidity probe. The standard product comes with two current outputs (0–20mA or 4–20mA), a system alarm relay, and three adjustable relays all with single-pole double-throw contacts, selectable fail-safe mode, and adjustable hysteresis. A display and push buttons form the user interface for data display, selection of units, ranges, setpoints, and special functions.

The RH-Plus MR2350 and/or MR2350-K are to be used only as specified by GE Measurement & Control Solutions. Use of an analyzer other than as specified may impair the safety precautions of the system.

1.2 Available Versions

The MR2350 is available in two mounting versions: wall mount and panel mount.

This manual generally describes the installation and wiring of the wall-mount version. Specific instructions for the panel-mount version are given where necessary.

The panel-mount version is available either with or without a protective and lockable door covering the unit's controls.

1.3 Unpacking and Inspection

Examine the shipping carton for broken or open packing, distortion, or any other evidence of mishandling. If inspection indicates damage to the unit or any of its components, notify the carrier promptly and request an inspection.

Move the carton to a clean work area and unpack the unit.

RH-Plus MR2350: The MR2350 carton should contain:

- RH-Plus MR2350 analyzer
- MDR3 probe with its cable
- CD with User's Manual
- Calibration certificate

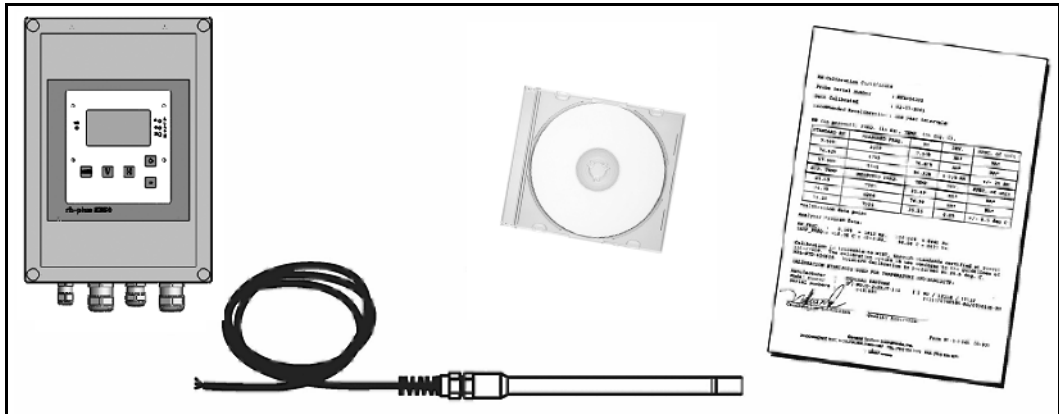

Figure 1: Unpacking the MR2350 Components

1.3 Unpacking and Inspection (cont.)

RH-Plus MR2350-K: The MR2350-K carton should contain:

- RH-Plus MR2350-K analyzer
- MDR3-K probe with its cable,
- or
- MDR3-N probe with its cables
- CD with User's Manual
- Calibration certificate

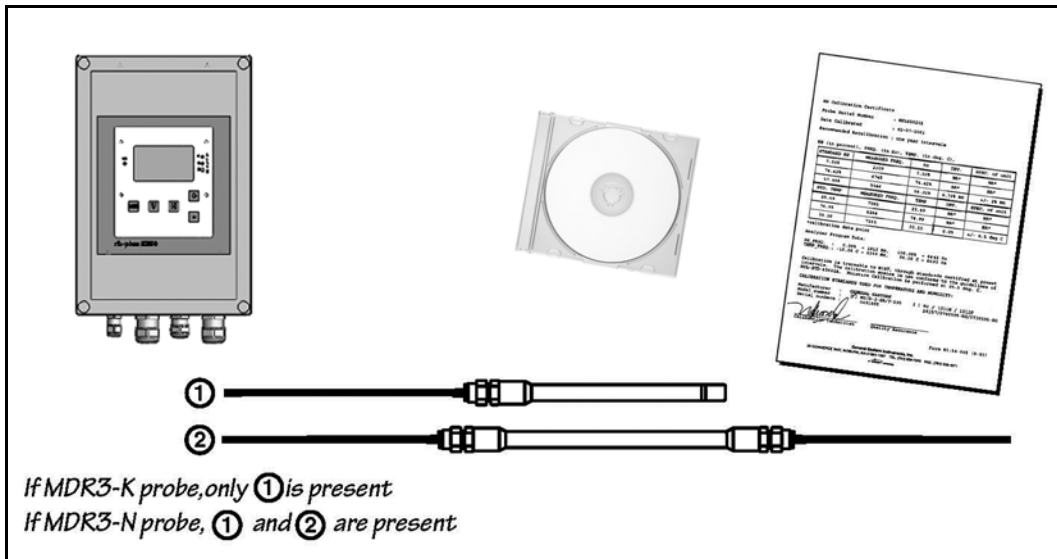

Figure 2: Unpacking the MR2350-K Components

1.4 Theory of Operation

Moisture and temperature sensor signals are converted within the probe to frequencies, allowing the use of shielded four-wire cable up to 1000 feet in length without noise interference. The raw frequencies can be displayed for troubleshooting, calibration and function control.

Dewpoint, calculated from relative humidity and temperature, can be selected as the primary measurement unit. Temperature and dewpoint are displayed in either °F or °C. The temperature measurement is also used for compensation of the RH sensor. Other units such as g/m^3 , g/kg and wet bulb temperature are also available.

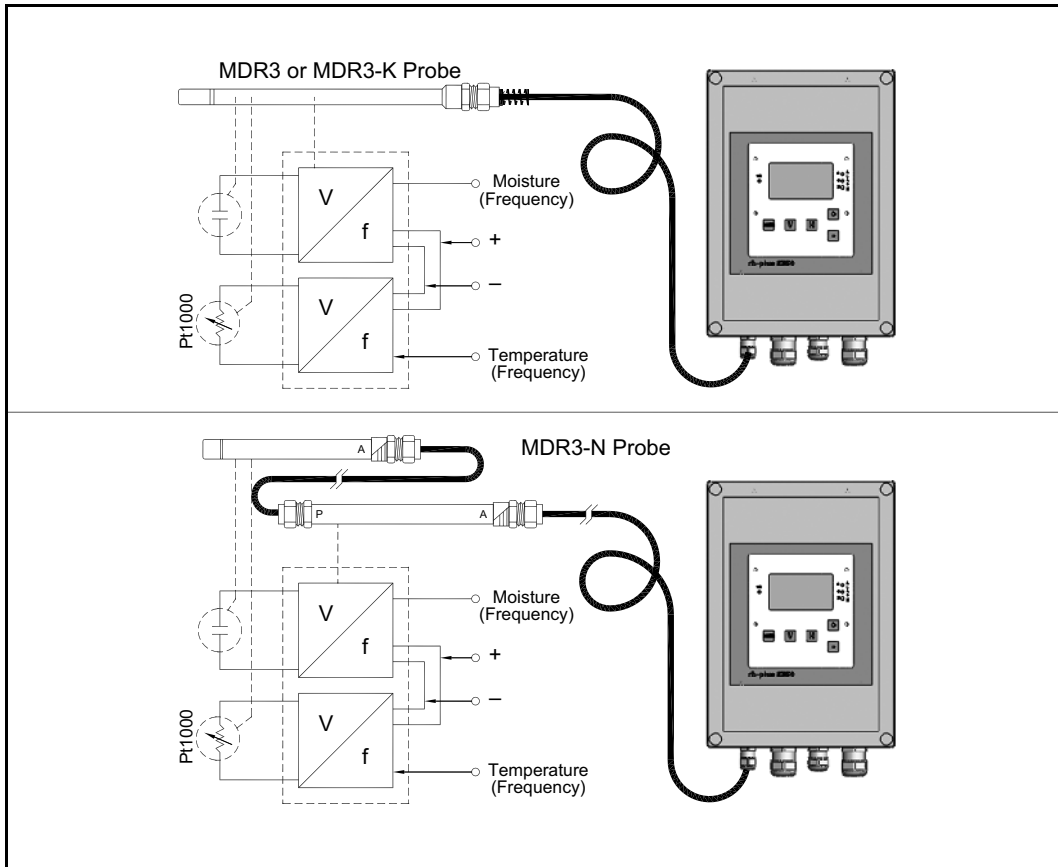

Figure 3: Theory of Operation

1.4 Theory of Operation (cont.)

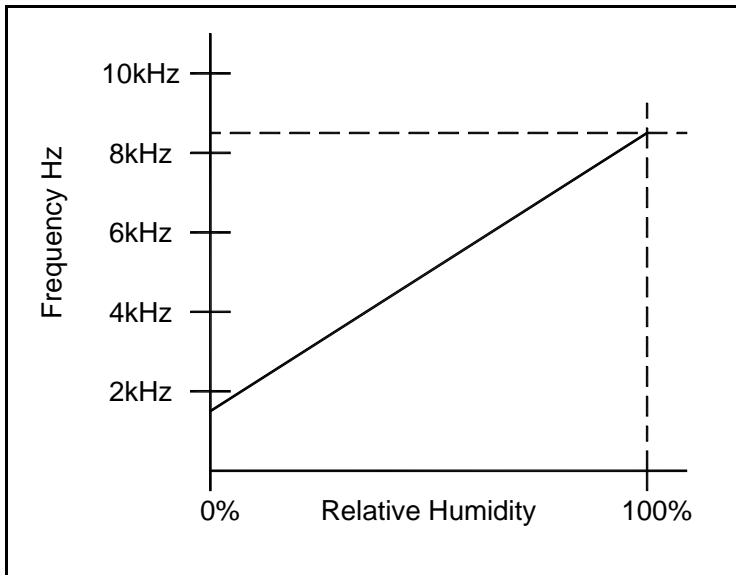
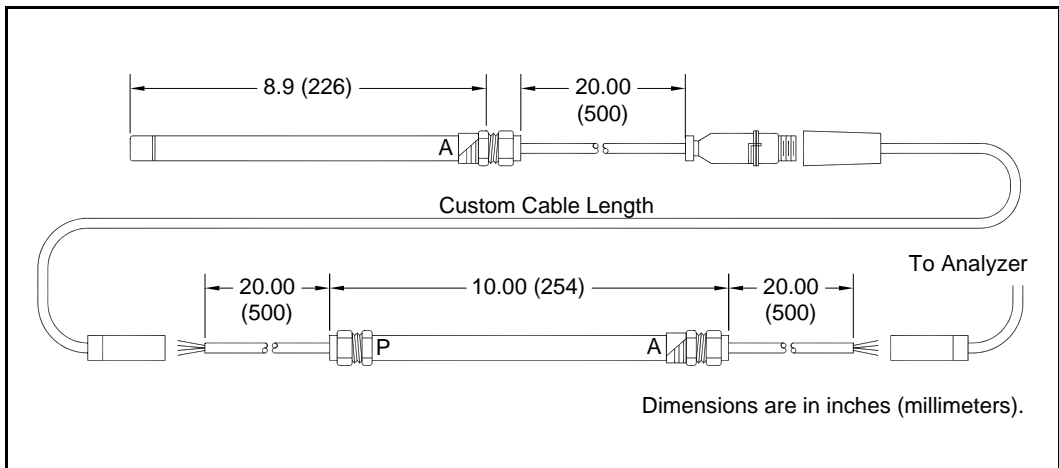
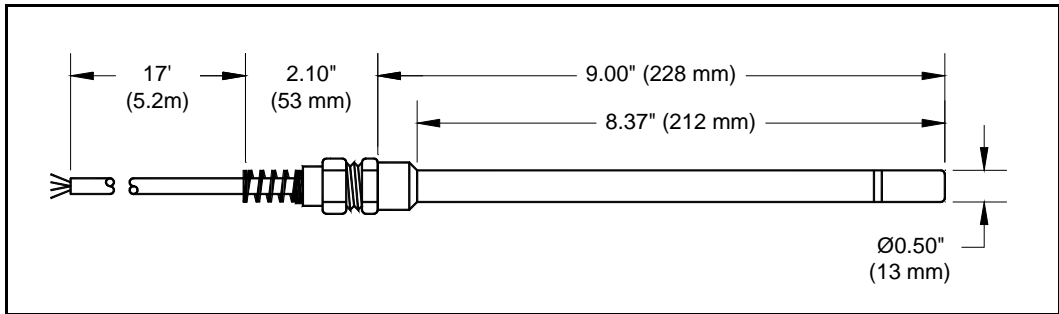

Figure 4: Typical RH Sensor Calibration Curve

1.5 Equipment Drawings



1.5 Equipment Drawings (cont.)

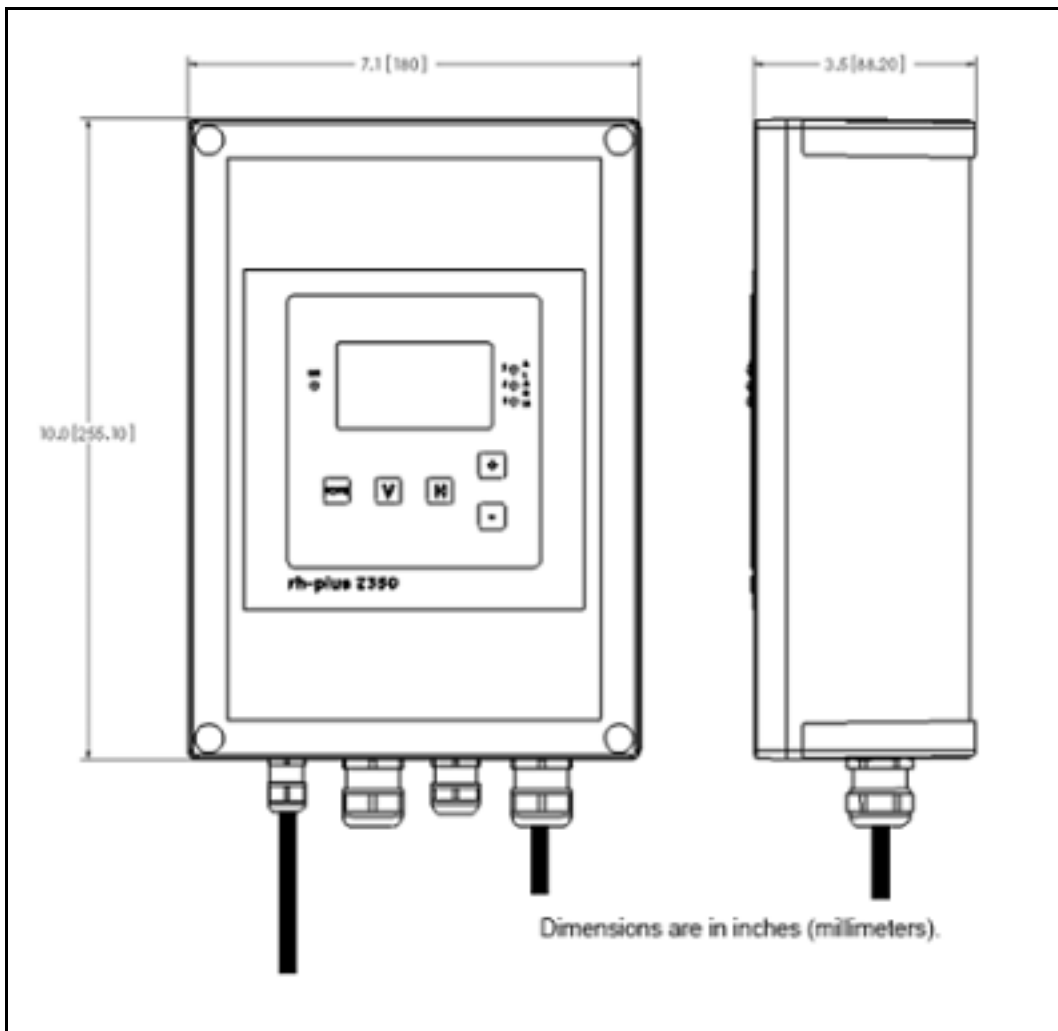

Figure 7: RH-Plus MR2350 or MR2350-K Analyzer

1.5 Equipment Drawings (cont.)

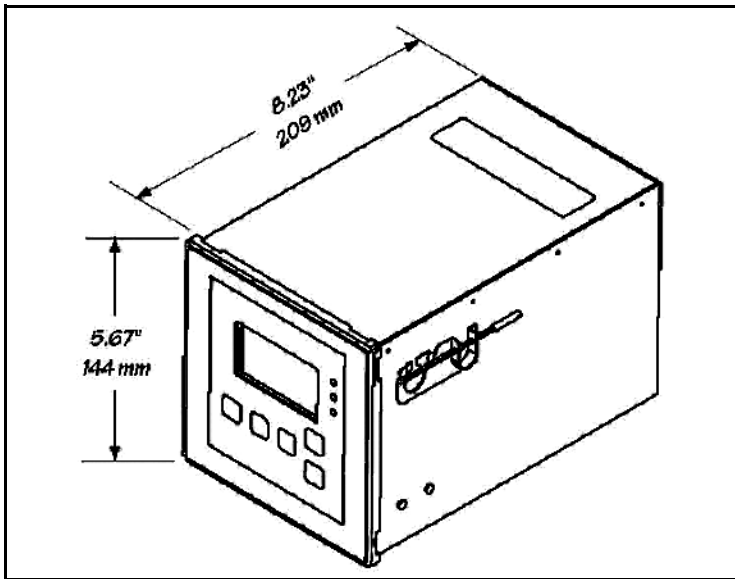

Figure 8: MR2350 Panel Mount Version

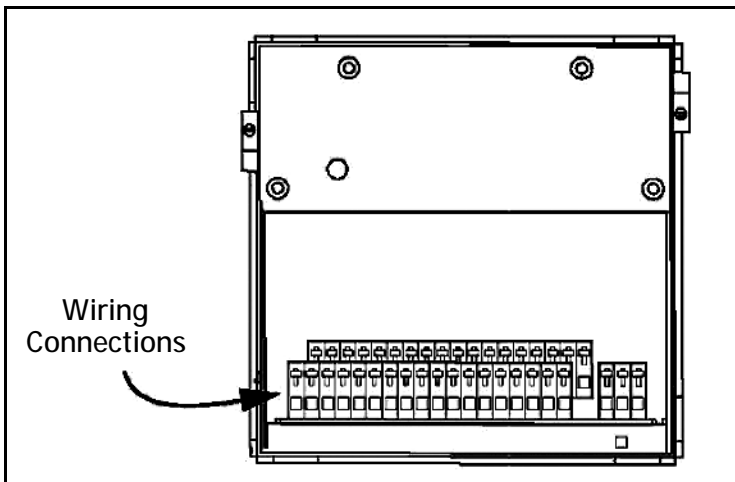

Figure 9: MR2350 Panel Mount Version (rear view)

Chapter 2. Installation

2.1 Mounting the Probe

It is preferable to mount the probe vertically so that the sensor tip points down. The probe is mounted in a ½” pipe thread connection or with a flange. Insure that the tip of the probe does not touch the inside wall of the pipe.

Adjust the ferrule (nylon or stainless steel*) for a probe insertion length of 1” (minimum) and tighten the compression fitting as follows:

1. Hand-tighten the nut.
2. Using a wrench, tighten the nut one and one-half additional turns.

With this procedure, the fitting is tight and can withstand pressure to 250 psig, provided a stainless steel ferrule is used.

Note: A nylon ferrule is used in systems without pressure. However, a 316 stainless steel ferrule is required for use in pressurized systems. Ensure that the probe being used has the appropriate fitting for the application.

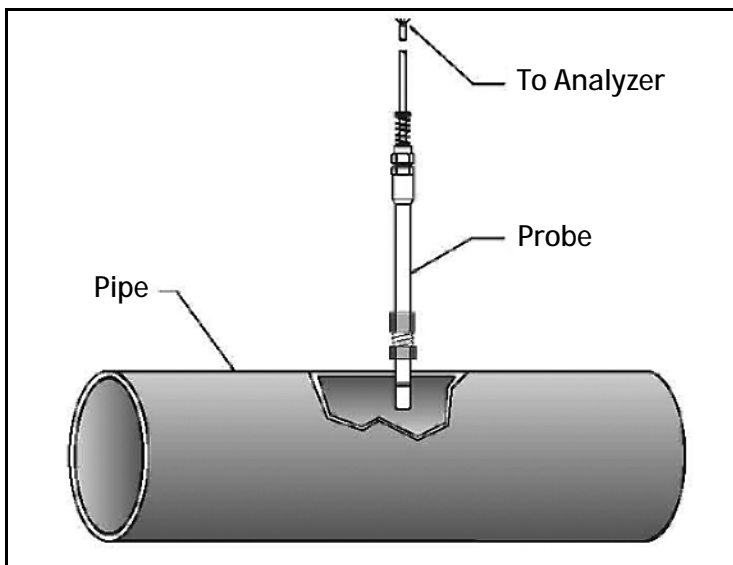

Figure 10: Probe Mounting

2.1.0a Probe Mounting Hardware

The following fittings are available for the MDR 3 probe. A 316 stainless steel ferrule is provided for use in pressurized systems. For non-pressurized systems, a nylon ferrule is available.

- 1/2" tube by 1/2" or 3/4" MNPT compression fitting; ferrule
- 3/4" x 16 "O" ring fitting x 1/2" tube 316 DD compression fitting
- Flange with 1/2" MNPT 1/2" tube compression fitting; adjustable probe insertion length
- For metric systems, a compression fitting with gasket and G 1/2 thread, DIN-ISO 228, is available.

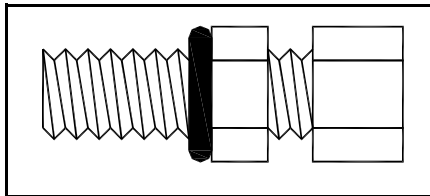

Figure 11: Compression Fitting

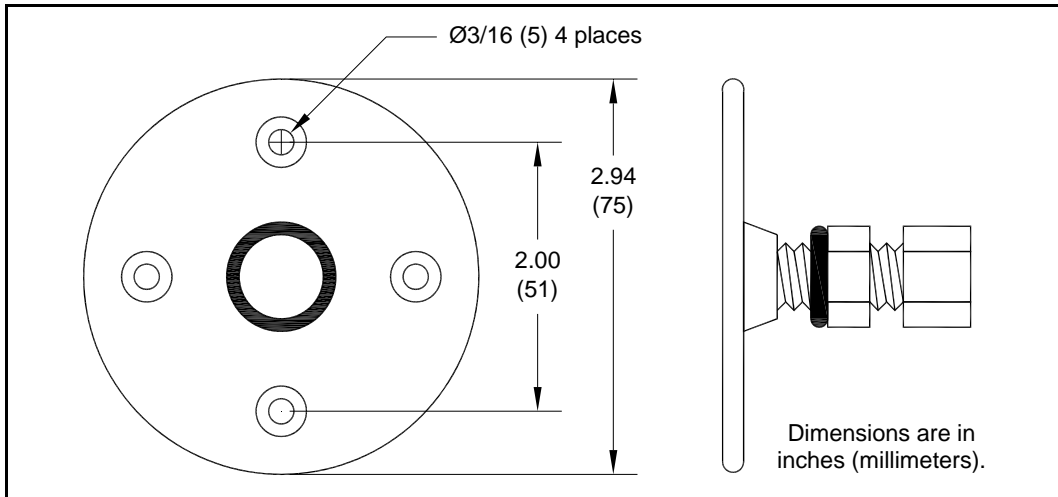

Figure 12: Flange with Gasket and Fitting

2.2 Opening the Wall-Mount Enclosure

To access the mounting points and electrical connections, open the case as follows (refer to Figure 13 below):

1. Ensure that no electrical power is present at the analyzer.
2. Loosen the four plastic screws securing the cover to the enclosure and remove the cover.

Note: The cover contains electronic components and is connected to the body of the analyzer.

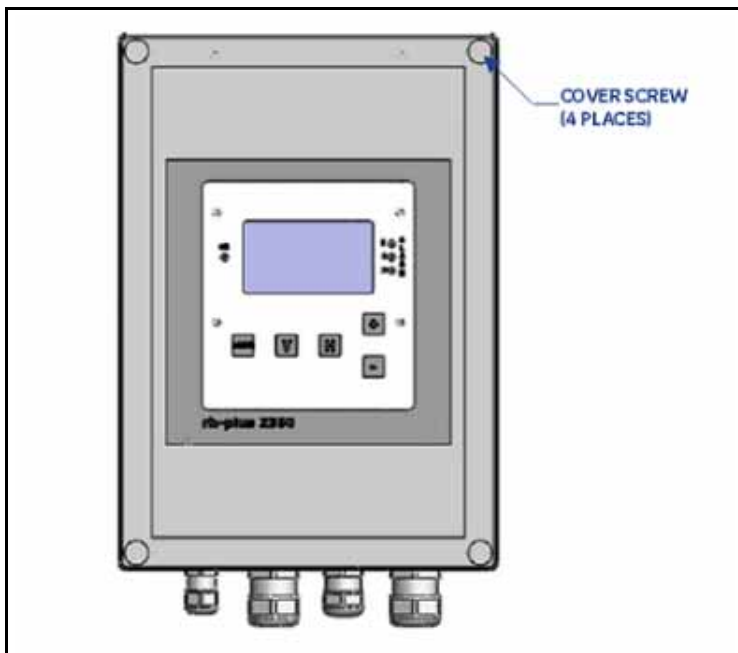

Figure 13: Opening the Wall-Mount Enclosure

2.3 Mounting the Wall-Mount Enclosure

The RH-Plus MR2350 and MR2350-K analyzers are for indoor use only. They should be mounted with appropriate hardware, and all wiring should conform to local electrical codes and standards.

A drilling template for locating the mounting holes is supplied with the unit. Choose mounting hardware appropriate for the application.

Locate the analyzer module so that the probe cable length will not exceed 1000 feet (300 meters).

1. Remove the cover as described in the previous section.
2. Mount the analyzer as shown in Figure 14 below.

Note: Insert the upper screw into the mounting hole and tighten it. Finally, insert the two lower screws.

3. Replace the cover (Maximum torque = 1.2 N-m (12.2 Kg-cm)).

To dismount the instrument, remove the cover. Remove the lower mounting screws. Then, remove the top mounting screws

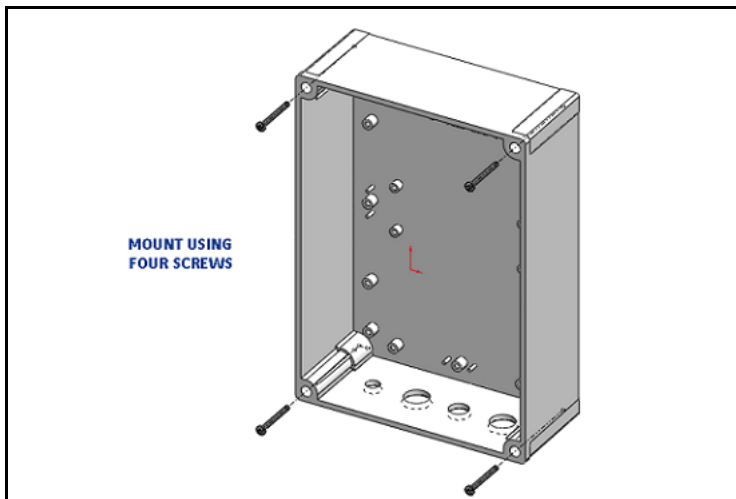

Figure 14: Mounting the Wall-Mount Enclosure

2.3 Mounting the Wall-Mount Enclosure (cont.)

4. Replace the covers.

To dismount the instrument, remove the two lower screws, pull the enclosure down to expose the top mounting tab, and remove the top screw.

2.4 Mounting the Panel-Mount Enclosure

The panel-mount version of the MR2350 is for indoor use only and is designed to be mounted in a square cutout in an equipment panel. The unit accommodates a wide range of panel thicknesses. Mount the unit as described below:

1. Make a cutout in the panel measuring 5.43" by 5.43" (138 by 138 mm).
2. Slide the unit into the cutout from the front of the panel.
3. From the rear side of the panel, slide the two mounting clamps into place on each side of the unit (see Figure 8 on page 8).
4. Tighten each clamp screw from the rear using a long screwdriver.

2.5 Wiring

Figure 15 below shows the MR2350/MR2350-K wiring compartment, showing typical connections for power and the MDR 3 probe.

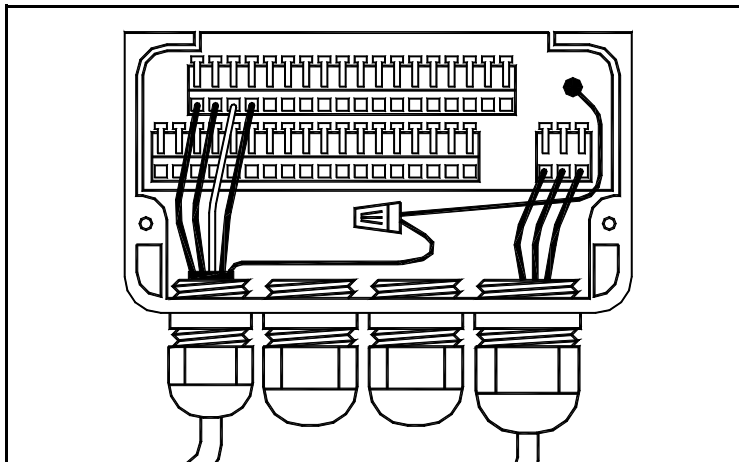

Figure 15: Wiring Compartment

2.5 Wiring (cont.)

Figure 16 below shows the complete wiring diagram. Wiring for the probe, power and outputs are shown in the following sections.

Wiring for the Panel Mount version is the same, except that the wiring connections are accessed from the rear of the unit.

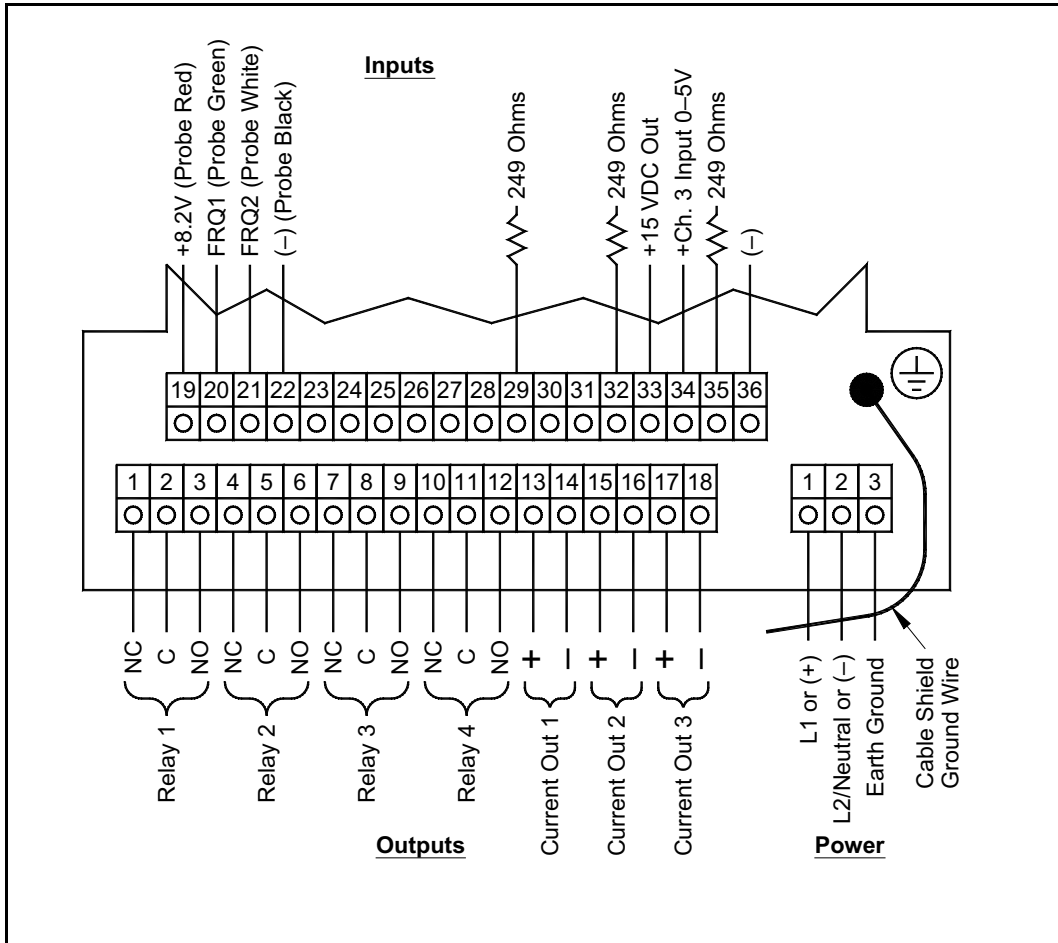

Figure 16: Wiring Connections

2.5 Wiring (cont.)

Notes:

1. MDR3 and MDR3-N(-K) Probe connections:
19 = RED; 20 = GREEN; 21 = WHITE; 22 = BLACK
2. Pin 33 is 15 VDC output power for external transmitter such as 4 to 20 mA loop power.
3. Auxiliary resistors of 249 Ohms are internal and connected to (-).
4. For 0/1 to 5V outputs:
Route 13, 15, 17 to 29, 32, 35 [0/1 to 5V against (-)].
5. To input from 4 to 20 mA loop-powered devices:
Connect transmitter (+) to +15 VDC out (33).
Connect (-) to resistor (35).
Jumper 35 to 34.
6. To input from active 4 to 20mA devices:
Connect (+) to resistor (35).
Connect (-) to 36.
Jumper 35 to 34.

2.6 Connecting the Probe

Open the analyzer's wiring cover as described on page 11.

Feed the cable through the left-most fitting. Maximum cable diameter for this fitting is 0.28 inches (7 mm). Individual wires should be fed between the levers of the first row, to ease insertion into the terminal holes.

Note: The default cable length is 17 feet (5 m). Other lengths are available on special order.

Connect the probe cable to the analyzer as shown in Figure 17 on page 16. Use a pointed instrument to push back the white nylon lever above each terminal, insert the stripped wire, and release the lever.

2.6 Connecting the Probe (cont.)

Connect the cable shield drain wire to the internal ground wire using the wire nut supplied. This connection is required to meet EMI/RFI specifications.

Securely tighten the bushing to provide strain relief for the cable. This requires two wrenches: one to hold the fitting's nut, and one to turn the fitting's bushing. Two wrenches are also needed to loosen the bushing to remove the cable.

CAUTION! Recheck all connections for security and correct placement of all wires. Severe damage can result from incorrect wiring.

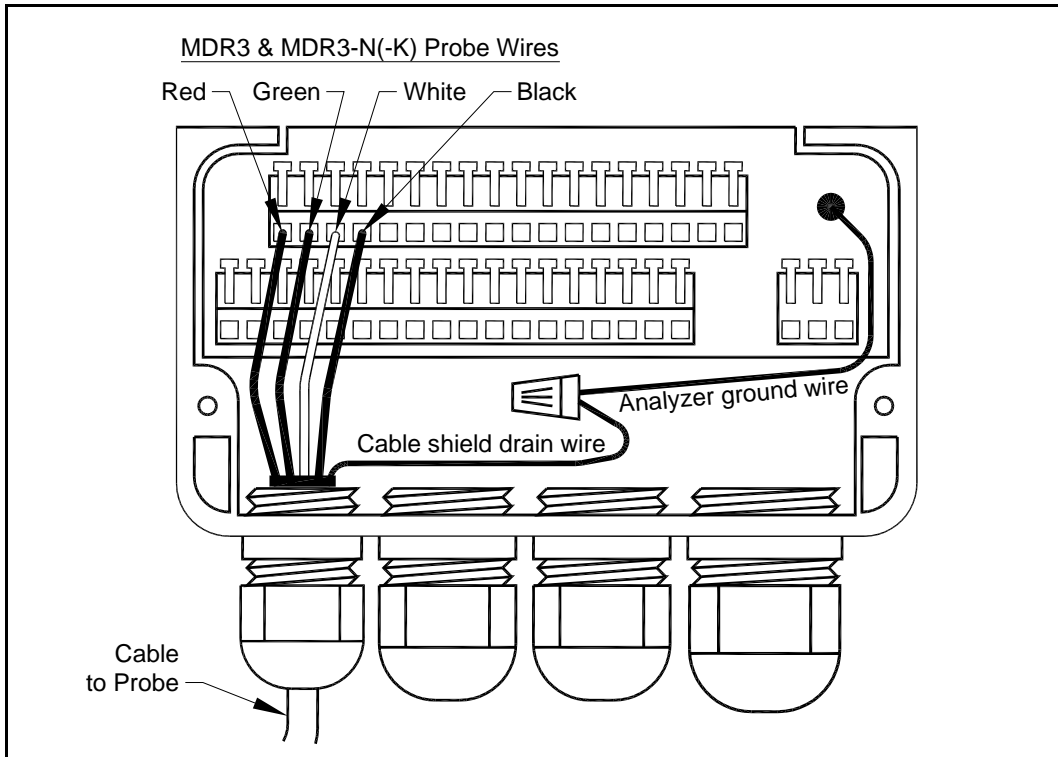

Figure 17: Wiring the Probe

2.6.1 Connecting the Power

2.6.1a AC Supply

To connect power wiring to the AC version of the analyzer:

1. Obtain an appropriate line cord (1A current capacity) that meets local codes.
2. Feed the line cord through the right-most fitting. Maximum cable diameter for the power fitting is 0.5" (12.5mm).
3. Tighten the bushing using two wrenches.
4. Connect the wires to the J2 terminal block: L1 input to Pin 1, L2/Neutral to Pin 2, and Earth Ground to Pin 3 as shown in Figure 18 below. Voltage ranges from 100 to 240 VAC are supported.

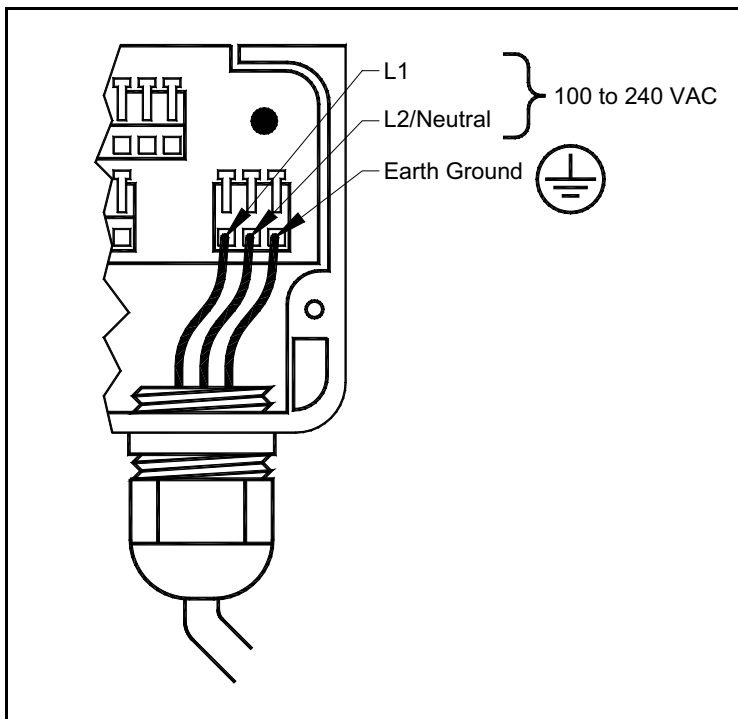

Figure 18: AC Power Wiring

2.6.1b DC Supply

To connect power wiring to the DC version of the analyzer:

1. Feed the cable through the right-most fitting. Maximum cable diameter for the power fitting is 0.5" (12.5mm).
2. Tighten the bushing using two wrenches.
3. Connect the wires to the J2 terminal block: Positive (+) to Pin 1, Negative (-) to Pin 2, and Earth Ground to Pin 3 as shown in Figure 19 below. Voltage ranges from 18 to 36VDC are supported.

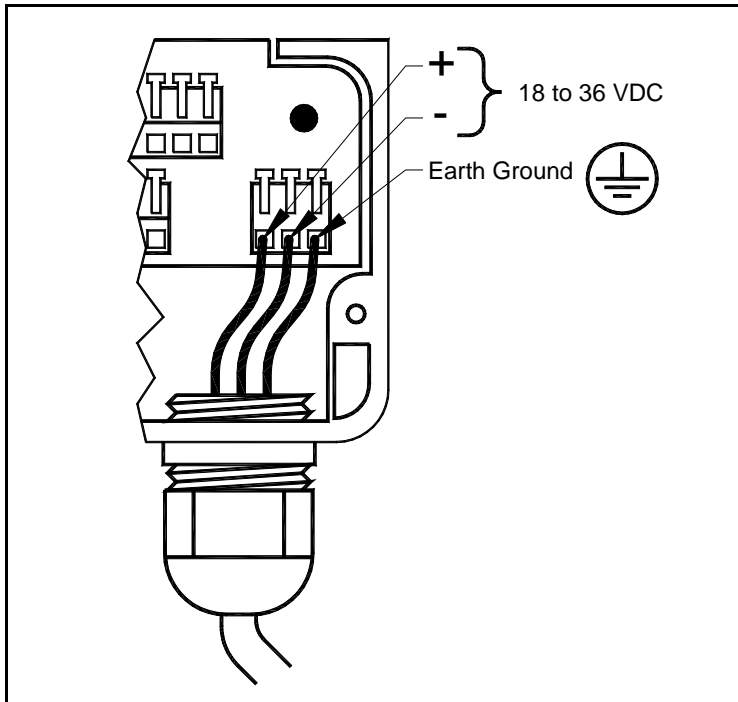

Figure 19: DC Power Wiring

2.6.2 Connecting Outputs

Cables for the relay and analog outputs are run through the two center fittings. Maximum cable diameter for the output fittings is 0.4" (10mm).

Shielded cable is required to meet RFI/EMI specifications. Connect the shield drain wire to the same analyzer ground wire used for the probe cable shield, using the wire nut provided.

2.6.2a Relays

Relay 1 is a system alarm that activates if an error condition occurs. Relays 2, 3 and 4 are programmable as alarms for the measured data. Wire as shown in Figure 16 on page 14 and Figure 20 below.

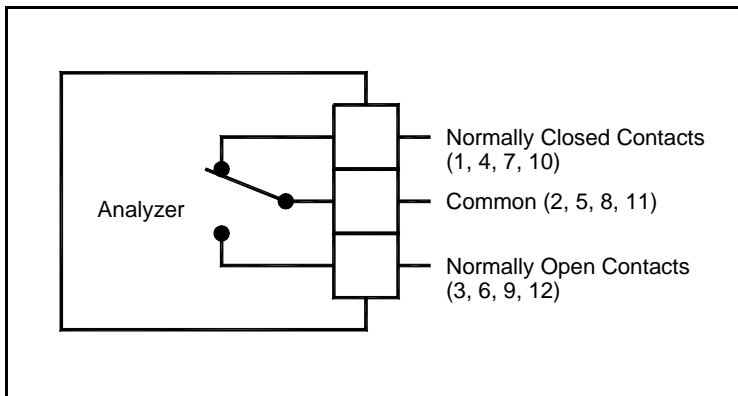

Figure 20: Relay Output Wiring

2.6.2b Current Outputs

The MR2350 and MR2350-K come with 1, 2 or 3 current outputs, depending on the ordering configuration. Wire as shown in Figure 16 on page 14.

The (-) outputs (terminals 14, 16, and 18) are all connected to system ground.

2.6.2c Voltage Outputs

Each current output can be configured as a voltage output by connecting the current output to an internal 249 ohm resistor (see Figure 21 below).

- For channel 1, connect the Channel 1 + output on terminal 13 to terminal 29.
- For channel 2, connect the Channel 2 + output on terminal 15 to terminal 32.
- For channel 3, connect the Channel 3 + output on terminal 17 to terminal 35.

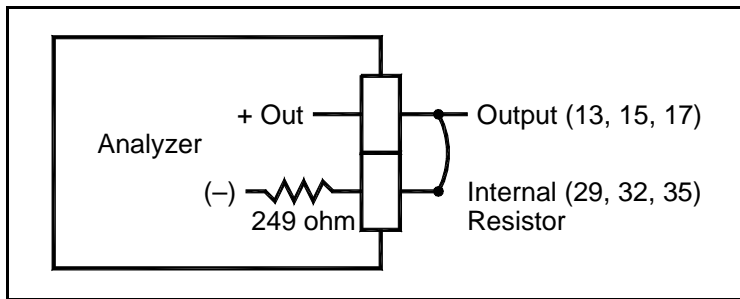

Figure 21: Voltage Output Wiring

2.6.3 Auxiliary Input Signals

One optional input (channel 3) can be used for pressure compensation, an external temperature probe, or other sensors. This input can be configured to accept 0–5 VDC or 4–20 mA signals.

2.6.3a 4 to 20mA Loop-Powered Device

To connect a 4 to 20 mA loop powered device:

1. Connect terminal 33 (+15V) to the transmitter's (+) wire.
2. Connect transmitter's (-) wire to terminal 35 (the 249 ohm resistor).
3. Connect terminal 35 to terminal 34 (analyzer input).

2.6.3a 4 to 20mA Loop-Powered Device (cont.)

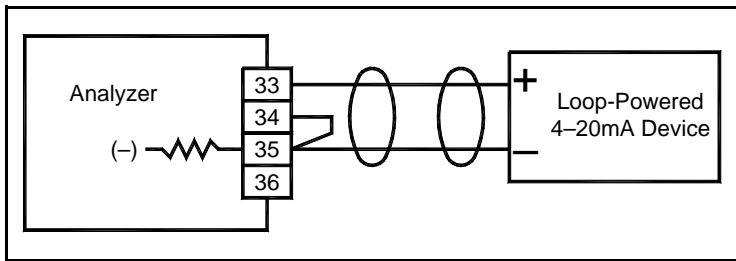

Figure 22: Loop-Powered Input

2.6.3b Active 4 to 20mA Device

To connect an active 4 to 20mA device:

1. Connect input (+) wire to terminal 35 (the 249 ohm resistor).
2. Connect input (-) wire to terminal 36 (ground).
3. Connect terminal 35 to terminal 34 (analyzer input).

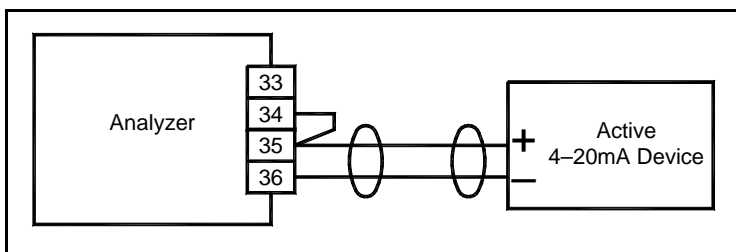

Figure 23: Active Input

Note: To connect a 4 to 20mA loop-powered device and set up an auxiliary input for Channel 1, see Appendix B.

2.7 Connecting RS-485

The unit's RS-485 output can be connected to an RS-232 device such as a Personal Computer.

2.7.1 Components Required

- RS-232 to RS-485 converter/interface unit
- 2-conductor cable terminating in a 2-position connector
- RS-232 cable

2.7.2 Connections

1. Connect the RS-232 cable from the PC comm port to the 232/485 converter.
2. Connect one wire of the 2-conductor cable from converter terminal A (or –) to P3, Pin 1 of the MR2350/MR2350-K.

Note: P3 is located to the left of the 18-terminal connector in the wiring compartment.

3. Connect the other wire from converter terminal B (or +) to P3, Pin 2.
4. Run the PC Terminal Emulator program with the following configuration:
1200 baud, 8 data bits, 1 stop bit, no parity, no flow control, TTY generic

An example of the PC display (the same values shown on the MR2350 display) follows:

```
46.8  26.3
46.8  26.2
46.9  26.2
46.9  26.3
46.8  26.4
```

Chapter 3. Programming and Operation

3.1 Introduction

The concept of programming and operating the unit is very simple: The unit's operation is controlled by a matrix of various functions (see Table 3 on page 29). Each display and setup operation is accessed by moving to the cell for that function. All operation and programming of the unit is controlled by moving through the matrix to the desired function.

3.2 Applying Power

When all wiring has been secured, power may be applied to the analyzer. (No power switch is supplied on the MR2350 or MR2350-K. The system turns on as soon as power is applied.) Upon power-up, the analyzer performs a software diagnostics test, and then displays humidity and temperature values.

3.3 Standard Configuration

Rh-Plus MR2350: The RH-Plus MR2350 analyzer is shipped with the following standard configuration:

- Normal display: RH in %; Temperature in °C.
- Alarm set points set to 30% and 30°C to allow for the specific setup.
- Output 1 is set to 0 to 100% RH (delivers 4 to 20mA); 110% at fault.
- Output 2, if ordered, is set to -15°C to +85°C (delivers 4 to 20 mA); 110% at fault.
- Matrix cell V9-H8 is set to "51" (matrix locked).
- Matrix cell V9-H9 is set to "0" (matrix read-only).

3.3 Standard Configuration (cont.)

RH-Plus MR2350-K: The MR2350-K analyzer is shipped with the following standard configuration:

- Normal display: Dewpoint in °C; Temperature in °C.
- Alarm set points are set to 25°C dewpoint.
- Output 1 is set to -15°C to 85°C dewpoint (delivers 4 to 20mA); -10% at fault.
- Output 2 is set to 0°C to +100°C (delivers 4 to 20 mA); -10% at fault.
- Matrix cell V9-H8 is set to “51” (matrix locked).
- Matrix cell V9-H9 is set to “0” (matrix read-only).

3.4 Controls

Operate the MR2350 or MR2350-K using the five push buttons shown below.

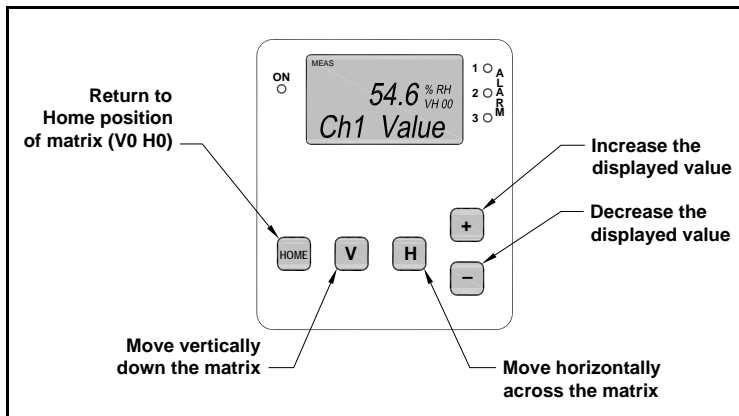

Figure 24: MR2350/MR2350-K Controls

3.5 The LCD Display

The unit's display contains four elements:

- Display mode (MEASure or SETUP)
- Display value (with units when appropriate)
- Matrix cell location
- Matrix location name (current function)

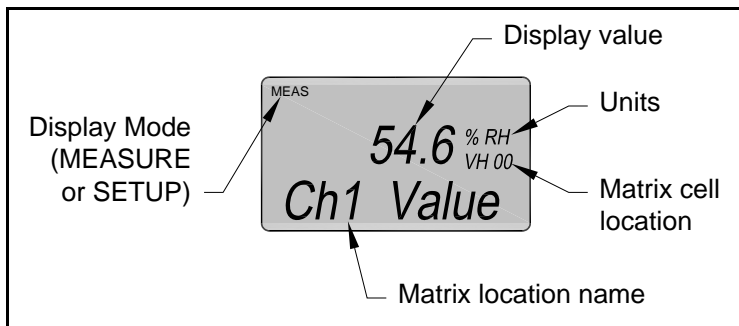

Figure 25: MR2350/MR2350-K LCD Elements

3.6 The Programming Matrix

3.6.1 Moving Through the Matrix

The MR2350 or MR2350-K display shows the current matrix location (the “cell”) at all times, using the vertical and horizontal coordinates. For example, the upper left cell location (0,0) is designated as VH 00 on the display, and as V0-H0 in this manual.

- Press the **V** button to move vertically down the matrix
- Press **H** to move horizontally across the matrix
- Press **HOME** to return to the home (upper left) cell of the matrix

For example, beginning at V0-H0 and successively pressing the **V** button leads the user to V1-H0, V2-H0, V3-H0, V4-H0, V5-H0, V6-H0, V7-H0, V8-H0, V9-H0 and back to V0-H0.

In the same manner, pressing the **H** button leads to V0-H1, V0-H2, etc. Using the **V** and **H** buttons, any matrix field can quickly be addressed.

The function of each cell is detailed beginning on page 32.

3.6.2 Entering Data

Some matrix cells are used for data display, and others are for programming and setup.

At any cell where a value can be changed by the user, the digit to be altered flashes and can be increased or decreased using the **+** and **-** buttons.

In some cases, the data to be entered comprises several digits. To move the flashing cursor to the next digit to the left, press **+** and **-** simultaneously.

***IMPORTANT:** Always enter a multi-digit number from right to left.*

3.6.3 “Display Only” Cells

Ten matrix cells are for display only and cannot be changed by the user.

Input (or programmable) fields have a flashing digit in the display, whereas “display only” fields do not.

The “display only” fields are as follows:

Table 1: “Display Only” Fields

Cell	Function
V0-H0	Display Moisture Value.
V0-H8	Display raw frequency reading of Channel 1.
V1-H0	Display Channel 2 value (usually temperature).
V1-H8	Display raw frequency reading of Channel 2.
V2-H0	Display Channel 3 value, e.g. pressure (Ch 3 is optional)*.
V2-H8	Display raw frequency reading of Channel 3.
V9-H0	Display Channel 1 Error Code.
V9-H1	Display Channel 2 Error Code.
V9-H2	Display Channel 3 Error Code.
V9-H3	Display Software Version.

*If inactive, the display shows dashes.

“Display only” cells are shown with a white background in the matrix in Table 3 on page 29.

Other cells allow user input for setup and control of the MR2350 or MR2350-K. These cells are shown with a light gray background in the matrix.

3.6.4 Function Guide

The matrix is organized in functional families by rows (V0 through V9). Below is a general description of these functional families indicating the row in which they can be found.

Table 2: Functional Families

Cell	Function
V0	Channel 1 data and selection of unit of measure
V1	Channel 2 data and selection of unit of measure
V2	Channel 3 data and selection of unit of measure (<i>option</i>)
V3	Constants
V4	Linearization (calibration)
V5	Channel 1 output setup
V6	Channel 2 output setup (<i>option</i>)
V7	Channel 3 output setup (<i>option</i>)
V8	Relay Setup
V9	Error indications, miscellaneous setup

3.6.5 Accessing the Matrix

Two matrix cells control access to the unit's programming functions. The matrix must be unlocked before any items can be changed.

To unlock the matrix, start at the **HOME** position and press **V** nine times and **H** eight times to move to cell V9-H8. Use the **+** and **-** buttons to enter the number 50.

Next, to allow access to the programming cells, press **H** to move to cell V9-H9. To allow access to the User Setup cells, enter 1.

Table 3: Programming Matrix

	H0	H1	H2	H3	H4	H5	H6	H7	H8	H9
V0	Display CH1 Value	Set CH1 Unit							CH1 Raw Reading	
CH1 Input									CH2 Raw Reading	
V1	Display CH2 Value	Set CH2 Unit							CH3 Raw Reading	
CH2 Input										
V2	Display CH3 Value	Set CH3 Unit								
CH3 Input										
V3	Pressure Constant	Pressure Constant Unit	Temperature Constant	Temperature Constant Unit						
Constants										
V4	Channel Select	Copy	Number of Linearization Points	Raw Reading	Calibration Value	Next Point	Commit			
User and Service										
V5	Input Channel Select	Minimum Value	Maximum Value	Output Type	Offset Enable		At Fault 1			
CH1 Output							At Fault 2			
V6	Input Channel Select	Minimum Value	Maximum Value	Output Type	Offset Enable		At Fault 3			
CH1 Output										
V7	Input Channel Select	Minimum Value	Maximum Value	Output Type	Offset Enable					
CH1 Output										
V8	Relay 2 Input Channel	Relay 2 Setpoint	Relay 2 Hysteresis Value	Relay 3 Input Channel	Relay 3 Setpoint	Relay 3 Hysteresis Value	Relay 4 Input Channel	Relay 4 Setpoint	Relay 4 Hysteresis Value	Alarm Setup
Relay Setup										
V9	CH1 Error	CH2 Error	CH3 Error	Software Version	Serial Output Enable	Relay Test	Relay Fail-safe Mode	Cycle through Active Channels while in VH00	Lock Matrix 50 = Unlock	Service Level
Misc. Setup										

Table 4: Matrix Value Descriptions - 1

Matrix Value	V0-H1 Moisture Unit	V1-H1 Temperature Unit	V2-H1 Pressure Unit	V8-H9 Alarm Setup*
0	Td °C	°C	bara	R4R3R2 = 000
1	Td °F	°F	barg	R4R3R2 = 001
2			psia	R4R3R2 = 010
3			psig	R4R3R2 = 011
4	g/m3		hPaa	R4R3R2 = 100
5	g/kg		hPag	R4R3R2 = 101
6	% RH			R4R3R2 = 110
7	Pressure Td °C			R4R3R2 = 111
8	Pressure Td °F			
9	Tw C (Wet Bulb)			
10	Tw F (Wet Bulb)			
11	mmHg (Vapor)			
12	hPa (Vapor)			
13	Temp Adj. %RH			

* 0 = alarm if data > setpoint; 1 = alarm if data < setup

Table 5: Matrix Value Descriptions - 2

Matrix Value	V5-H3	V5-H4	V5-H7	V9-H6	V9-H9
	V6-H3	V6-H4	V6-H7	Fail-safe Mode	Service Level
	V7-H3	V7-H4	V7-H7		
	Output Type	Offset	At Fault		
0	Off	0-20 mA	-10%	Energized	Read Only
1	0/4-20 mA	4-20 mA	+110%	De-energized	User Setup
2			Hold		

3.6.6 Locking the Matrix

All of the entries in the matrix can be locked to prevent unauthorized or accidental changes to the unit's operation. It is recommended that the matrix be kept locked except when changes are being made. The matrix is locked by entering any number other than 50 in cell V9-H8. The programming examples later in this manual refer to this section.

To lock the matrix, follow the steps in Table 6 below:

Table 6: Steps to Lock the Matrix

Press Button	Resulting Display	Comments
HOME	VH 00	Start at "home" cell.
V (9 times)	VH 90	Move to setup row.
H (8 times)	VH 98	Move to the "unlock" cell.
+ or – (if necessary)	any number other than 50	"50" unlocks the matrix.

3.6.7 Unlocking the Matrix

To unlock the matrix, follow the steps in Table 7 below:

Table 7: Steps to Unlock the Matrix

Press Button	Resulting Display	Comments
HOME	VH 00	Start at "home" cell.
V (9 times)	VH 90	Move to setup row.
H (8 times)	VH 98	Move to the "unlock" cell.
+ or – (if necessary)	50	"50" unlocks the matrix.

3.6.8 Matrix Field Details

Not all of the cells in the matrix are used. Below are descriptions for the specific cells that are used to control the operation of the instrument.

Note: To assist in setting a value in a cell, the cursor (the flashing digit to be altered) can be moved from digit to digit, right to left, by pressing the + and – buttons simultaneously.

Table 8: Operation Cells Descriptions

Cell	Function
<i>Row V0: Channel 1 data and selection of units of measure</i>	
V0-H0	Displays moisture, in units selected in cell V0-H1
V0-H1	Enter a number from the list below to select the desired moisture units to be displayed in V0-H0. This setting also affects the analog outputs and alarm setpoints. 0 = Td °C, dewpoint temperature 1 = Td °F, dewpoint temperature 4 = g/m ³ 5 = g/kg 6 = % RH 7 = Pressure Td °C 8 = Pressure Td °F 9 = Tw °C, wet bulb temperature 10 = Tw °F, wet bulb temperature 11 = mmHg water vapor pressure 12 = hPa water vapor pressure 13 = Temperature-adjusted % RH (special function)
V0-H8	Displays the raw frequency value corresponding to the Channel 1 input (moisture content).
<i>Row V1: Channel 2 data and selection of units of measure</i>	
V1-H0	Displays data for Channel 2, normally the temperature.
V1-H1	Enter the units of measure for temperature: 0 for °C or 1 for °F.
V1-H8	Displays the raw digital frequency value from the Channel 2 input (temperature).

Table 8: Operation Cells Descriptions (Continued)

Cell	Function
<p align="center">Row V2: Channel 3 data and selection of unit of measure</p> <p align="center">The Channel 3 input is optional. Contact the factory for information on using this input.</p>	
V2-H0	Displays data for channel 3.
V2-H1	Enter the unit of measure for channel 3.
V2-H8	Displays the raw digital value from the Channel 3 input (if option is installed).
<p align="center">Row V3: Compensation constants</p>	
V3-H0	<p align="center">A pressure value from 0.1 to 999.9 bar can be entered to compensate concentration units such as g/kg.</p> <p><i>Example 1:</i> Concentration units are pressure independent. However, the rh sensor measures the water vapor pressure. If the process pressure is increased, for example, by 10 atmospheres (10 times), the water vapor pressure will also increase by a factor of 10, (Dalton's Law depicts that partial pressures increase by the same amount as the total pressure). The sensor monitors this correctly, and as a result a pressure constant of 10 must be entered in cell V3-H0 to correct for this law of physics. If the process pressure is fluctuating, a pressure transducer can be connected to the channel 3 input providing real-time pressure compensation. (This requires factory setup).</p> <p><i>Example 2:</i> Consider a process pressure at 100 bar that uses a by-pass system which reduces the pressure to near atmospheric pressure. (Note that the MDR 3 is pressure rated up to 17 bar or 250 psi). The measured dewpoint will be much lower under these conditions according to Dalton's Law (see V3-H0). Entering 100 in V3-H0 and selecting 7 (for °C) or 8 (for °F) in V0-H1 will cause the process pressure dewpoint to be displayed in V0-H0.</p>
V3-H1	<p align="center">If V3-H0 is used, enter the units of measure for that cell. See cell V0-H1 for a list of the available units.</p>
V3-H2	<p align="center">A constant temperature to be used in calculations for temperature compensation can be entered here. If a temperature measurement is provided by the probe on Channel 2, or by another sensor on Channel 3, any temperature constant entered in this field will be ignored.</p>
V3-H3	<p align="center">If a temperature has been entered in cell V3-H2, enter the units of measure for the temperature constant here: 0 = °C, 1 = °F</p>

Table 8: Operation Cells Descriptions (Continued)

Cell	Function
<p style="text-align: center;">Row V4 Linearization (Probe calibration)</p> <p><i>Note: New 2350 systems (analyzer and probe) are shipped with matched components and there is normally no need to enter calibration values. The steps in V4-H0 through V4-H6 are necessary only when connecting a spare probe or a re-calibrated probe. The calibration process uses cells V4-H0 through V4-H6. For channel 1 of the MDR3 rh probe, two calibration points are entered: the rh in cell V4-H4, and the corresponding frequency delivered by the probe's electronics in matrix field V4-H3. (Up to 15 calibration points can be entered in case of special calibration at multiple points.) Channel 2 is calibrated in the same way. Enter the low and high frequency readings and temperature values. Details are shown in Chapter 4.</i></p>	
V4-H0	In this cell, enter the channel that is to be calibrated.
V4-H1	Enter 1. (Entering 0 would copy the entire calibration data contents of the previous channel into the current channel).
V4-H2	Enter the number of calibration points to be used (normally 2).
V4-H3	Enter the frequency value of selected point.
V4-H4	Enter the rh % value of the selected point.
V4-H5	Displays the number of the calibration point currently being entered. Press the + button to increase this number and immediately jump to V4-H3 to enter the next point. After the last point has been entered, move to V4-H6.
V4-H6	Press + to increase the value to "1" to confirm and store the displayed calibration numbers. System then jumps immediately to V4 H0.

Table 8: Operation Cells Descriptions (Continued)

Cell	Function
Row V5 Channel 1 analog output setup <i>The cells in this row configure the Channel 1 analog output. See page 38 for details.</i>	
V5-H0	Select which input channel will drive output channel 1. Enter 1, 2, or 3.
V5-H1	Program the output range: enter the minimum rh % value (corresponding to 0/4 mA).
V5-H2	Program the output range: enter the full-scale rh % value (corresponding to 20 mA).
V5-H3	Define the output type: 0 turns the output off, 1 turns it on.
V5-H4	Offset the output range: 0 = 0 to 20 mA 1 = 4 to 20 mA Voltage output (with a 249 Ohm load resistor connected) will be 0 to 5V or 1 to 5V.
V5-H7	Configure the current to be output if there is a system error: entering 0 sets the output to –10% or 3.6 mA for the event; 1 sets the output to 110% or 22 mA for the event; 2 freezes the output at the last measured value in the event.
Row V6: Channel 2 analog output setup (optional)	
V6-Hx	Apply the same sequence described for Row V5 to output 2.
Row V7: Channel 3 analog output setup (optional)	
V7-Hx	Apply the same sequence described for Row V5 to output 3.

Table 8: Operation Cells Descriptions (Continued)

Cell	Function																																													
Row V8: Relay setup																																														
<i>The cells in this row configure the three alarm relay outputs. Step by step instructions begin on page 40.</i>																																														
V8-H0	Select which input channel will control relay 2. Enter 1, 2 or 3.																																													
V8-H1	Enter the alarm set point for relay 2. For a negative value, use the – button to go below 0.																																													
V8-H2	Enter relay 2's hysteresis value as a percentage of the measurement range (example: 1 = 1%).																																													
V8-H3	Select which input channel will control relay 3. Enter 1, 2 or 3.																																													
V8-H4	Enter the alarm set point for relay 3. For a negative value, use the – button to go below 0.																																													
V8-H5	Enter relay 3's hysteresis value as a percentage of the measurement range (example: 1 = 1%).																																													
V8-H6	Select which input channel will control relay 4. Enter 1, 2 or 3.																																													
V8-H7	Enter the alarm set point for relay 4. For a negative value, use the – button to go below 0.																																													
V8-H8	Enter relay 4's hysteresis value as a percentage of the measurement range (example: 1 = 1%).																																													
V8-H9	<p>For each relay, designate whether it should trigger when the measured value is greater than the set point or lower than the set point (high/low alarm). If 0 is chosen, the relay alarms when the measured value is higher than the set point. If 1 is chosen, the relay alarms when the measured value is lower than the alarm set point. Choose the settings for each relay, find the combination below, and enter a number from 0 to 7.</p> <table style="margin-left: auto; margin-right: auto;"> <thead> <tr> <th></th> <th><u>Rly 4</u></th> <th><u>Rly 3</u></th> <th><u>Rly 2</u></th> <th></th> </tr> </thead> <tbody> <tr> <td></td> <td>0</td> <td>0</td> <td>0</td> <td>= 0</td> </tr> <tr> <td></td> <td>0</td> <td>0</td> <td>1</td> <td>= 1</td> </tr> <tr> <td></td> <td>0</td> <td>1</td> <td>0</td> <td>= 2</td> </tr> <tr> <td></td> <td>0</td> <td>1</td> <td>1</td> <td>= 3</td> </tr> <tr> <td></td> <td>1</td> <td>0</td> <td>0</td> <td>= 4</td> </tr> <tr> <td></td> <td>1</td> <td>0</td> <td>1</td> <td>= 5</td> </tr> <tr> <td></td> <td>1</td> <td>1</td> <td>0</td> <td>= 6</td> </tr> <tr> <td></td> <td>1</td> <td>1</td> <td>1</td> <td>= 7</td> </tr> </tbody> </table>		<u>Rly 4</u>	<u>Rly 3</u>	<u>Rly 2</u>			0	0	0	= 0		0	0	1	= 1		0	1	0	= 2		0	1	1	= 3		1	0	0	= 4		1	0	1	= 5		1	1	0	= 6		1	1	1	= 7
	<u>Rly 4</u>	<u>Rly 3</u>	<u>Rly 2</u>																																											
	0	0	0	= 0																																										
	0	0	1	= 1																																										
	0	1	0	= 2																																										
	0	1	1	= 3																																										
	1	0	0	= 4																																										
	1	0	1	= 5																																										
	1	1	0	= 6																																										
	1	1	1	= 7																																										

Table 8: Operation Cells Descriptions (Continued)

Cell	Function
<i>Row V9 Miscellaneous setup</i>	
V9-H0	Displays the error number in case of malfunction in Channel 1. See troubleshooting section for details.
V9-H1	Displays the error number in case of malfunction in Channel 2. See troubleshooting section for details.
V9-H2	Displays the error number in case of malfunction in Channel 3. See troubleshooting section for details.
V9-H3	Displays the software version (e.g., 1.02).
V9-H4	Enable the displayed channel data to be transmitted on the RS-485 communication port once per second, when non-zero.
V9-H5	<p>Perform a relay test.</p> <p>Enter 1 to cycle the system alarm.</p> <p>Enter 2 to cycle relay 2.</p> <p>Enter 3 to cycle relay 3.</p> <p>Enter 4 to cycle relay 4.</p>
V9-H6	Select the fail safe mode: Enter 0 for relays to be de-energized when an alarm is present. Enter 1 for relays to be energized when an alarm is present. Relay number 1 (the system alarm) is also controlled by this setting.
V9-H7	Auto-sequence function. Entering 1 causes the display to sequence through the active input channels. For example, using the MDR 3 probe, the display would show the rh % value for 5 seconds, then the temperature value for 5 seconds and back to rh % for 5 seconds and so on. Entering 0 turns the sequencing function off.
V9-H8	Entering any number other than 50 locks all matrix fields from entering values to prevent tampering.
V9-H9	This field restricts access to programming. Entering 0 puts the instrument into a read-only mode where only certain matrix locations can be read. Entering 1 allows access to User Setup functions. These functions can be modified only if 50 is entered in field V9-H8.

3.7 Analog Output Setup

The following steps configure the Channel 1 analog output (matrix row V5). For Channel 2, use row V6; for Channel 3, use row V7.

To configure a channel:

1. Assign an input channel to control this output.
2. Set the minimum and maximum values.
3. Turn the output on.
4. Select the output current offset (0–20 mA or 4–20 mA).
5. Configure the system fault mode.

First, unlock the matrix by entering “50” into V9-H8 as described above, and then follow the steps in for Channel 1.

To set up Channel 2 or 3, follow the same sequence using row V6 for Channel 2, or row V7 for Channel 3.

When the programming is finished, it is recommended that the matrix be locked by entering any number other than 50 into cell V9-H8 as described on page 31.

Refer to Figure 16 on page 14 for wiring to the internal 249 ohm resistor(s) to facilitate measurements.

Table 9: Analog Output Setup (Channel 1)

	Press Button	Resulting Display	Comments
Access Channel 1 output row.	HOME	VH 00	Move to home cell.
	V (5 times)	VH 50	Move to "Channel 1 output" row.
Assign input channel	+ or – (if necessary)	1	Select Channel 1 (or other, if desired).
Enter minimum value	H	VH 51	Move to "minimum value" cell.
	+ or – (if necessary)	Desired minimum value	Enter the measured value that should produce 0 or 4 mA output.
Enter maximum value	H	VH 52	Move to cell.
	+ or – (if necessary)	Desired maximum value	Enter the measured value that should produce 20 mA output.
Turn the output on	H	VH 53	Move to output type.
	+ or – (if necessary)	1	Turn output on (0 would turn the output off).
Enter offset	H	VH 54	Move to "offset" cell
	+ or – (if necessary)	0 or 1	0 = 0-20 mA 1 = 4-20 mA
Enter the fault mode	H	VH 57	Move to cell.
	+ or – (if necessary)	0, 1 or 2	0 = -10% 3.6 mA if fault 1 = +110% 22 mA if fault 2 = Hold freeze if fault

3.8 Relay Setup

The following steps configure Relay 2 using cells V8-H0, V8-H1 and V8-H2.

- For Relay 3, use cells V8-H3, V8-H4 and V8-H5.
- For Relay 4, use cells V8-H6, V8-H7 and V8-H8.

The following steps are required:

1. Assign an input channel to control this relay.
2. Enter the set point.
3. Enter the hysteresis.
4. For each relay, choose whether it triggers when the measured value is above or below the set point.

First, unlock the matrix by entering “50” into V9-H8 as described on page 31, and then follow the steps given in Figure 10 on the next page for programming all relays.

Table 10: Relay Setup

	Press Button	Resulting Display	Comments
Access relay setup row.	HOME	VH 00	Move to home cell.
	V (8 times)	VH 80	Move to "relay 1" cell.
Assign input channel	+ or – (if necessary)	1	Select Channel 1 (or other, if desired).
Enter set point	H	VH 81	Move to "set point" cell.
	+ or – (if necessary)	Desired set point	
Enter hysteresis	H	VH 82	Move to cell.
	+ or – (if necessary)	Desired hysteresis	
Move to Relay 2	H	VH 83	Move to "relay 2" cell.
	+ or – (if necessary)	1	Select channel 2 (or other, if desired).
Assign input channel			
Enter "set point"	H	VH 84	Move to "set point" cell
	+ or – (if necessary)	Desired set point	
Enter hysteresis	H	VH 85	Move to cell.
	+ or – (if necessary)	Desired hysteresis	
Move to Relay 3	H	VH 86	Move to "Relay 3" cell.
	+ or – (if necessary)	1	Select channel 3 (or other, if desired).
Assign input channel			
Enter "set point"	H	VH 87	Move to "set point" cell.
	+ or – (if necessary)	Desired set point	

Table 10: Relay Setup (Continued)

	Press Button	Resulting Display	Comments
Enter hysteresis	H + or – (if necessary)	VH 88 Desired hysteresis	Move to cell.
Move to Alarm Setup	H	VH 89	Move to cell.
Enter alarm setup code	+ or –	code (0-7; see below)	Code selects whether the relay's alarm is above or below the set point. This single value controls the three relays.

3.8 Relay Setup (cont.)

For the final entry choose 0 or 1 for each relay, and use Table 11 on the next page to combine these into a single digit (0 – 7).

If 0 is chosen, the relay alarms measured value is higher than the set point. If 1 is chosen, the relay alarms measured value is lower than the alarm set point. Choose the settings for each relay, find the combination in Table 3-11 on the next page, and enter a number from 0 to 7.

3.8 Relay Setup (cont.)

Table 11: Relay Settings

Relay 4	Relay 3	Relay 2	
0	0	0	= 0
0	0	1	= 1
0	1	0	= 2
0	1	1	= 3
1	0	0	= 4
1	0	1	= 5
1	1	0	= 6
1	1	1	= 7

When the programming is finished, it is recommended that the matrix be locked by entering any number other than 50 into cell V9-H8 as described on page 31.

Operation of the relay contacts is summarized in Table 12 below. Relay 2 (the first programmable relay, which controls alarm LED #1) is shown as an example.

Table 12: Relay Contact Operation (Relay 2)

Power	Alarm Condition	Relay Coil	NO (Normally Open) Contact	NC (Normally Closed) Contact	LED #1
Off	---	De-energized	Open	Closed	---
On	No Alarm	Energized	Closed	Open	Off
On	Relay 2 in alarm state	D-energized	Open	Closed	On

Chapter 4. Calibration

4.1 Introduction

The MR2350 or MR2350-K system is shipped with the analyzer precalibrated to the MDR 3 probe shipped with it. The calibration procedure is necessary only when the probe has to be replaced or recalibrated.

A calibration sheet is supplied with each probe. A sample sheet is shown in Figure 26 below. Verify that the serial number on the calibration sheet matches the serial number on the probe. Frequency numbers from the sheet are copied into the analyzer during the procedure. Only the numbers circled below are used in the procedure.

GE Sensing

RH Calibration Certificate

Probe Serial Number : **RH1850201**

Date Calibrated : 02-07-2001

Recommended Recalibration : one year intervals

RH (in percent), FREQ. (in Hz), TEMP. (in deg. C),

STANDARD RH	MEASURED FREQ.	RH	DEV.	SPEC. of unit
7.50%	2309	7.50%	NA*	NA*
74.42%	6745	74.42%	NA*	NA*
57.05%	5546	56.32%	0.73% RH	+/- 2% RH
STD. TEMP	MEASURED FREQ.	TEMP	DEV.	SPEC. of unit
25.49	7085	25.49	NA*	NA*
74.99	8264	74.99	NA*	NA*
35.20	7315	35.15	0.05	+/- 0.5 deg C

*calibration data point

Analyzer Program Data:

RH FREQ. : 0.00% = 1812 Hz, 100.00% = 8441 Hz
 TEMP_FREQ.: -10.00 C = 6240 Hz, 90.00 C = 8622 Hz

Calibration is traceable to NIST, through standards certified at preset intervals. The calibration system in use conforms to the guidelines of MIL-STD-45662A. Moisture Calibration is performed at 25.5 deg. C.

CALIBRATION STANDARDS USED FOR TEMPERATURE AND HUMIDITY:

Manufacturer : GENERAL EASTERN
 Model number : [X] M3/D-2-SR/T-100 [] M2 / 1211H / 1112P
 Serial numbers : 0491095 24157/0740595-RG/0730595-RG

[Signature]
 Calibration Technician Quality Assurance

Form #1-14-045 (8-93)



Probe
Serial
No.

Calibration
data

Figure 26: Sample Calibration Sheet

4.2 Calibration Procedure

In the steps below, when a cell is accessed to enter a number, the correct number may already be there. If this is the case, move on to the next step and continue.

Table 13: Calibration Procedure Steps

	Press Button	Resulting Display	Comments
Unlock matrix	HOME	VH 00	Start at "home" cell.
	V (9 times)	VH 90	Move to setup row.
	H (8 times)	VH 98	Move to "unlock" cell.
	+ or – (if necessary)	50	"50" unlocks the matrix.
Enter "User Setup" mode	H	VH 99	Move to cell.
	+ or – (if necessary)	1	"1" is user setup mode.
Access calibration row	HOME	VH 00	Move to home cell.
	V (4 times)	VH 40	Move to "channel select" cell.
Select channel	+ or – (if necessary)	1	Select channel 1.
Access "copy" function	H	VH 41	Move to "copy" cell
Enable it	+ or – (if necessary)	1	"1" enables copy function of selected channel.
No. of calibration points	H	VH 42	Move to next cell.
	+ or – (if necessary)	2	Number of calibration points (normally 2 for the MDR3 probe)

Table 13: Calibration Procedure Steps (Continued)

	Press Button	Resulting Display	Comments
Enter frequency #1	H	VH 43	Move to next cell.
	+ or -	from supplied calibration data (e.g., 1812)	Frequency for Point 1
Enter RH Value #1	H	VH 44	Move to next cell.
	+ or -	From supplied calibration data (usually 0.0)	RH for Point 1
Next point	H	VH 45	Point No. is incremented and unit immediately moves back to cell V4-H3 to enter the next point.
	+	VH43	
Enter frequency #2	+ or -	from supplied calibration data (e.g. 8441)	Frequency data for Point 2
	H	VH 44	Move to cell.
Enter RH value #2	+ or -	from supplied calibration data (usually 100.0)	RH for Point 2
	H	Commit 1	Ready to store values.
All done Commit values	+	VH 40	Cal values stored; ready for next channel.

4.2 Calibration Procedure (cont.)

Repeat this process, specifying Channel 2 and entering temperature calibration data, lower frequency first.

When this programming is complete, leave user setup mode, as shown in Table 14 below.

Table 14: Leaving User Setup

Leave "User Setup" mode	HOME	VH 00	Start at "home" cell.
	V (9 times)	VH 90	Move to setup row.
	H (9 times)	VH 99	Move to service level cell.
	+ or - (if necessary)	0	"0" is read-only mode.

Finally, it is recommended that the matrix be locked by entering any number other than 50 into cell V9-H8 as described in Table 15 below.

Table 15: Locking the Matrix

Lock Matrix	H (9 times)	VH 98	"Lock/unlock" cell.
	+ or - (if necessary)	any number other than 50	Lock matrix.

Chapter 5. Troubleshooting and Maintenance

5.1 General Problems

5.1.1 Invalid Loop Current

If the loop current shown on the display or current meter is outside the normal range of 4–20 mA (or 0–20 mA, if selected), a problem is indicated.

5.1.1a If the Unit of Measure is RH (%):

Note: *0% and 100% relative humidity are absolute limits.*

A defective sensor or a malfunction of the sensor electronics may generate sensor signal values that are out of the 0% to 100% range.

Solution: Expose the sensor to ambient air, which normally possesses a relative humidity well away from 0% and 100% (i.e., between 10% and 90%). If the current returns to the 4 to 20 mA range, check the calibration with salt solutions. If an error is still indicated, consult the factory.

5.1.1b If the Unit of Measure is Dewpoint:

The process dewpoint is out of range.

Solution 1: If the dewpoint is above +85°C (+185°F), the current will go to 22mA (if that fault mode is selected). Apply dry air for a few minutes. If the dewpoint doesn't decrease, consult the factory.

Solution 2: If the dewpoint is below –15°C (+5°F), the current will go to 3.6mA (if that fault mode is selected). Move the sensor into a wetter environment for a few minutes. If the dewpoint doesn't increase, the cause may be a defective sensor assembly or an electronics malfunction. Consult the factory.

The same approach is valid for the other available units of measure and for the second channel (temperature).

5.1.2 Slow Response Time

System response time may become slow if the probe filter is dirty.

Solution: Remove the protective filter cap by turning it counter-clockwise, then clean it with air flow or solvent. If the sensor filter is contaminated, clean it in hot water with a brush.

5.2 Error Codes

Error conditions are indicated by the flashing of the **ALARM** LED for the affected channel, and the channel value is displayed as dashes. To display the error code for the detected condition, access matrix cell V9-H0 for Channel 1, V9-H1 for Channel 2, or V9-H2 for Channel 3.

A typical error code display is shown in Figure 27 below.



Figure 27: Typical Error Code Display

5.2 Error Codes (cont.)

Displayed error codes are described in Table 16 below:

Table 16: Error Codes

Code	Description
0	No error
4	Maximum frequency exceeded
8	Zero frequency
16	Output under range
32	Output over range
64	Vapor Pressure - under range
128	Vapor Pressure - over range

These error codes are often displayed in combination as the sum of two codes listed above.

Specific problem situations are detailed in Table 17 below:

Table 17: Problem Situations

Input Signals		Resulting Outputs		Error Codes	
Channel 1 Moisture	Channel 2 Temperature	Output 1 Moisture	Output 2 Temperature	Channel 1	Channel 2
normal	normal	< 4 mA	< 4 mA	16	16
normal	normal	> 20 mA	> 20 mA	32	32
normal	missing	on	on	0	16
normal	missing	off	off	0	0
missing	normal	on	on	88	40
missing	normal	off	off	72	8

5.2.1 Notes

Error codes are driven by the output signal values.

Even if the sensor signal is within the calibration range, the output range may be exceeded at the low or high end, generating the error code.

When an error code is generated, the affected channel displays four dashes instead of a numeric value.

- To read a Channel 1 error code, go to cell V9-H0.
- To read a Channel 2 error code, go to cell V9-H1.
- To read a Channel 1 raw sensor frequency, go to V0-H8. If it is within the calibration range (0 to 100%), widen the output range (cells V5-H1 and/or V5-H2).
- To read a Channel 2 raw sensor frequency, go to V1-H8. If it is within the calibration range (-10 to +90°C), widen the output range (cells V6-H1 and V6-H2).

5.2.2 Correcting Problems

If the signal is missing, check for broken wires or loose connections on the probe cable. Connect another probe, if available.

Make sure that the output range values correspond to the unit of measure for the channel. For example, if temperature units are changed from °C to °F, the output range must also be changed.

5.3 Signal Test

If the system is not operating correctly, use the following procedure to determine whether the analyzer or the probe needs repair:

1. Remove the wiring cover as described on page 11.

WARNING! This test may involve using tools near the exposed AC power wiring on the right side of the wiring area.

2. Connect an oscilloscope to the white probe wire.
3. Observe the signals on terminal 21 (the white wire) and terminal 20 (green wire).
Figure 28 below shows the correct response:

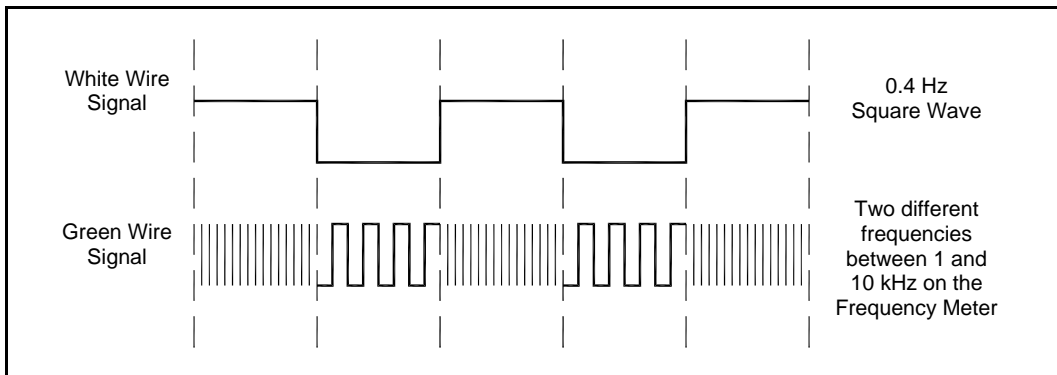

Figure 28: Oscilloscope Display

5.3 Signal Test (cont.)

Note: If the terminal 21 signal deviates from the above or is missing, disconnect the white wire from the terminal strip and measure again, directly on terminal 21.

If the terminal 21 signal still deviates from the correct signal or is missing, return the analyzer to the factory.

4. If the terminal 21 signal is correct, reconnect the white wire to terminal 21 and disconnect the green wire from terminal 20. Then check the green wire signal.

Note: If the green wire signal is correct, return the analyzer to the factory.

If the green wire signal deviates or is missing, return the probe to the factory.

5.4 Probe Replacement

If it is necessary to remove or replace the probe:

1. Open the analyzer covers as described on page 11 and disconnect the wires.
2. Loosen the bushing using two wrenches as described on page 15 and remove the cable.
3. When replacing the probe, follow the instructions shown on page 15. Be sure to ground the cable shield.
4. If the probe has been replaced with a different probe, be sure to follow the calibration procedure (see *Calibration* on page 46), using the calibration sheet included with the new probe.

Appendix A. Specifications

A.1 MR2350/MR2350-K Analyzer

A.1.1 Electronics:

State of the art micro-controller providing utmost flexibility to meet application needs.

A.1.2 Standard Inputs:

Two (moisture and temperature) from MDR3 probe

A.1.3 Optional Input:

For pressure transducer providing live pressure compensation or other analyzer.

Signals: 0/1 to 5V, 0/4 to 20 mA loop powered, or 4 to 20 mA.

A.1.4 Moisture Probe:

Interconnects with MDR3xx probe.

A.1.5 User Interface:

5 push-buttons, easy configuration using programming matrix.

A.1.6 Display:

Alpha-Numeric LCD, displays measured value with units of measure, matrix location and programming instructions, error indication with error code if malfunction occurs; user selectable scanning feature alternating the display every five seconds through active channels (3 max)

A.1.7 European Compliance:

Complies with EMC directive 2004/108/EC and LVD 2006/95/EC

A.1.8 Units of Measure

A.1.8a *Moisture:*

RH%, dewpoint °C, °F, g/m³, g/kg, Tw °C, °F (wet bulb temperature), vapor pressure in hPa, mmHg, process pressure calculated dewpoint °C, °F, RH% calculated from separate temperature value (needs temperature measurement using the optional input)

A.1.8b *Temperature:*

°C, °F

A.1.8c *Pressure:*

For optional input used with a pressure transducer:

bara, barg, psia, psig, hPaa, hPag

A.1.9 Analog Outputs:

Three, each configurable to any input, 0/4 to 20 mA, load resistance <500 ohms, 0/1 to 5 V, source resistance 249 ohms, user selectable range, user selectable condition in case of error to 110%, -10% or hold at last measured value.

A.1.10 Digital Outputs:

Four relays (SPDT dry contacts rated at 250 VAC, 2.5 A,

PAC = 300 VA, cos phi > 0.7, PDC 100W, 100 VDC

One relay is system alarm.

Three relays are configurable to any input; failsafe mode: energized/de-energized selectable, programmable hysteresis, high/low alarm selectable

A.1.11 Serial Output:

RS485, update rate once per second.

A.1.12 Program:

Non-volatile memory

A.1.13 Data:

EEPROM

A.1.14 Cable Entry:

Metric cable glands M12, 2XM16, M20

A.1.15 Operational/Storage Temperature:

-10°C to 50°C (14°F to 122°F)

A.1.16 Supply Power:

100 to 240 VAC, optional 18 to 36 VDC

A.1.17 Power Consumption:

- 5.8 VA for line-powered units
- 2.2 W for DC-powered units

A.1.18 Enclosures:

Wall mount, IP54, Type 12, separate connection compartment, Type 4X, Type 7, panel mount

A.1.19 Weight:

1 kg (2.2 lb)

A.2 Panel Mount Enclosure

A.2.1 Material:

Black anodized aluminum

A.2.2 Dimensions:

144 mm x 144 mm panel (5.67" x 5.67")

A.2.3 Depth:

Maximum protrusion at the rear of the panel: 209 mm (8.23")

Maximum protrusion at the front of the panel: 8.25 mm (0.32") with bezel

Maximum protrusion at the front of the panel: 32 mm (1.26") with door

A.2.4 Panel cutout:

138 mm x 138 mm (5.43" x 5.43")

A.2.5 Wiring:

Same configuration as the wall mount unit, wired in the rear

A.2.6 Mounting:

Insert from front into the panel, install the clamps, tighten the clamp screws from the rear against the panel using a long screwdriver.

A.2.7 Front panel surface:

Overlay with membrane buttons integrated LEDs and clear window for display

A.3 MDR3 Probe

A.3.1 Sensing element:

Silicon-based polymer, capacitance principle, IC electronics

A.3.2 RH range:

0 to 100%

A.3.3 RH accuracy:

$\pm 2\%$ in the range of 0 to 90%; $\pm 3\%$ in the range of 90 to 100%

A.3.4 DP range:

5°F to 185°F (–15°C to +85°C)

A.3.5 DP accuracy:

Better than $\pm 1.8^\circ\text{F}$ ($\pm 1^\circ\text{C}$) for dewpoints $> 32^\circ\text{F}$ (0°C) at 77°F (25°C)

A.3.6 Standard Operating Temperature:

5°F to 185°F (–15°C to +85°C)

A.3.7 Temperature Accuracy:

$\pm 0.9^\circ\text{F}$ ($\pm 0.5^\circ\text{C}$)

A.3.8 Maximum Operating Pressure:

250 psig (17.2 bar)

A.3.9 Signal Transmission:

Moisture and temperature converted to frequencies, allowing up to 1000 ft (300 m) of standard four-wire shielded cable

A.3.10 Probe Cable Connector:

17 ft (5 m) cable permanently attached, or junction box with screw terminals

A.3.11 Sensor Electronics:

Integrated circuitry with a platinum RTD temperature sensor

A.3.12 Probe Tube:

316 stainless steel, 0.5” diameter, 8.9” long

A.3.13 Standard Probe Mounting:

1/2” Tube x 1/2” NPT, 3/4” NPT, G12, 3/4”-16 compression fitting or flange

A.3.14 Sensor Guard:

Rugged, removable easy-to-clean, 100 micron sintered 316L stainless steel filter; additional hydrophobic filter on sensor element allowing penetration of water vapor but not water droplets

A.3.15 Weight:

1 lb (0.5 kg)

A.3.16 Approval:

ATEX II 1G, (EEx ia) IIC T4, 203°F (90°C), ATEX II 1D 212°F (100°C), Class I, Division 1, Groups A, B, C & D using zener barrier kit IS 20 ST from GE or equivalent

A.4 MDR3-N(-K) Probe

A.4.1 Sensing Element:

Silicon-based polymer, capacitance principle, IC electronics

A.4.2 RH Range:

0 to 100%

A.4.3 RH Accuracy:

±2% within the range of 10 to 90%

A.4.4 Repeatability:

Better than 0.5% RH

A.4.5 Hysteresis:

Less than 0.9%

A.4.6 Dewpoint Range:

5°F to 185°F (–15°C to +85°C)

A.4.7 Dewpoint Accuracy:

From 10 to 90% RH; ±3.6°F (±2°C);

From 0 to 10% RH and from 90 to 100% r.h.: ±5.4°F (±3°C)

A.4.8 Operating Temperature:

14°F to 212°F (–10°C to +100°C)

A.4.9 Temperature Accuracy:

±0.9°F (±0.5°C)

A.4.10 Maximum Operating Pressure:

90 psig (6 barg) from all sides

A.4.11 Sensor Electronics:

Integrated circuitry with built-in platinum temperature element

A.4.12 Radiation Resistance

max. 45 Gray

A.4.13 Signal Transmission:

Moisture and temperature converted to frequencies, two twisted pairs of individually shielded cable allowing up to 1000 ft. (300 m) distance (R max.: 25 ohms)

A.4.14 Standard Cable Length MDR3-K:

20" (50 mm) with Harting connector, Type Han, metal; protection IP 65 (in closed position)

A.4.15 Standard Cable Length MDR3-N:

All cables are 20" (50 mm); optional Harting connector, Type Han, metal; protection IP 65 (in closed position) is provided.

A.4.16 Probe Tube MDR3-N:

Stainless steel 1.4571; ½" (12.7 mm) dia.; length 8.9" (226 mm) housing the sensor only.

A.4.17 Probe Tube MDR3-K:

Stainless steel 1.4571; ½" (12.7 mm) dia.; length 8.9" (226 mm) housing the sensor and electronics.

A.4.18 Location of Probe Electronics (MDR3-N):

Resides in a remote 10" (254 mm) long, 0.625" (15.9 mm) dia. stainless steel tube; with 20" (500 mm) cable on each side, to be interconnected by user.

A.4.19 Location of Probe Electronics (MDR3-K):

Resides within sensor tube (no remote electronics required).

A.4.20 Sensor Guard:

Removable stainless (316) sintered filter cap, additional hydrophobic filter on sensor element allowing penetration of water vapor but not water droplets.

A.4.21 Weight:

0.5 lbs (256 g)/tube

A.4.22 Approvals:

Meets CE requirements; EEx ia IIC T4 approved by CENELEC and FM using zener barriers.

Appendix B. Channel 1 Auxiliary Input Setup

B.1 Wiring

To set up an auxiliary input for Channel 1 with a loop-powered 4-20mA device, see Figure 29 below, and make the following connections:

1. Connect 33 (+15V) to the transmitter (+) wire.
2. Connect (-) wire to terminal 29 (249 ohm internal resistor).
3. Connect terminal 29 to 28 (CH1 analyzer input).

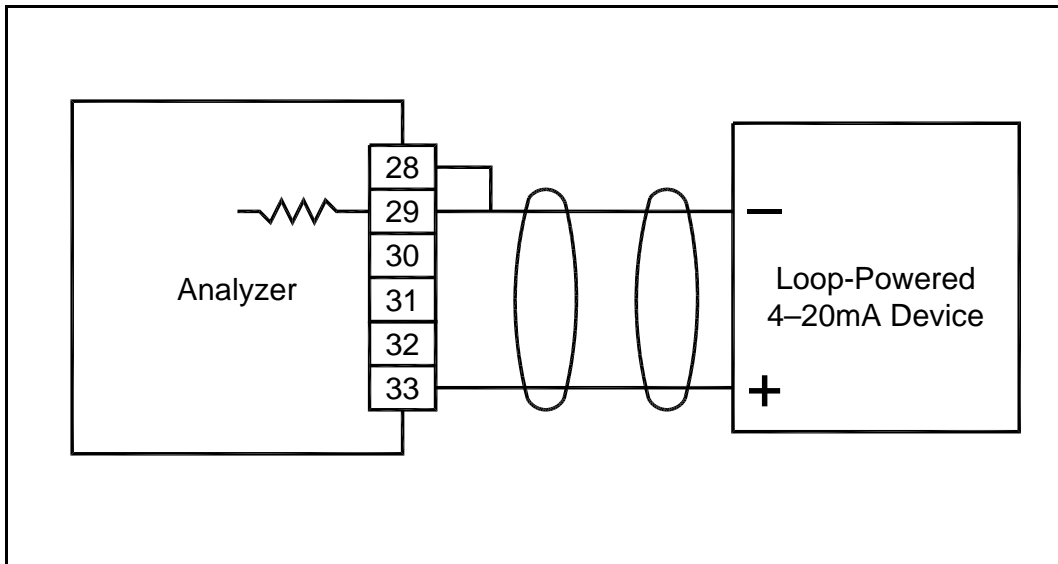

Figure 29: Channel 1 Auxiliary Input Setup

B.2 Configuration

To configure Channel 1 as an input channel, enter the following values:

Table 18: Calibration Procedure Steps

	Press Button	Resulting Display	Comments
Unlock matrix	HOME	VH 00	Start at "home" cell.
	V (9 times)	VH 90	Move to setup row.
	H (8 times)	VH 98	Move to "unlock" cell.
	+ or – (if necessary)	50	"50" unlocks the matrix.
Enter "User Setup" mode	H	VH 99	Move to cell.
	+ or – (if necessary)	2	"2" is user setup mode.
Access calibration row	H (2 times)	VH 02	Move to next cell.
Select channel	+ or – (if necessary)	1	Select channel 1.
Access "copy" function	H	VH 03	Move to "copy" cell
Enable it	+ or – (if necessary)	1	"1" enables copy function of selected channel.
Set CH1 Temperature Compensation Channel	H	VH 04	Move to next cell.
	+ or – (if necessary)	0	Select none.
Set CH1 Pressure Compensation Channel	H	VH 05	Move to next cell.
	+ or –	0	None
Set Temperature Adjusted RH/ Temp. Channel	H	VH 06	Move to next cell.
	+ or –	0	None
Display CH1 value	H	VH 01	Set channel 1 unit
	+ or –	6	% RH

Table 18: Calibration Procedure Steps (Continued)

	Press Button	Resulting Display	Comments
Select channel	+ or – (if necessary)	VH 40	Move to next cell.
		1	Select Channel 1
Access “copy” function	H	VH 41	Move to “copy” cell.
Enable it	+ or – (if necessary)	1	“1” enables copy function of selected channel
No. of linearization points	H	VH 42	Move to next cell.
	+ or – (if necessary)	2	Number of linearization points = 2
Raw reading	H	VH 43	Move to next cell.
	+ or –	4.00	Set to 4 mA.
Calibration Value	H	VH 44	Move to next cell.
	+ or – (if necessary)	0	RH value at 4 mA
Commit	H	VH 46	Move to next cell.
	+ or –	1	Same value
Next point	H	VH 45	Move to next cell.
	+ or – (if necessary)	2	Next point
Raw reading	H	VH 43	Move to next cell.
	+ or –	20.00	Set to 20 mA.
Calibration value	H	VH 44	Move to next cell.
	+ or – (if necessary)	100.0	RH value at 20 mA
Commit	H	VH 46	Move to next cell.
	+ or –	1	Save value.

Note: At the end, make sure that VOHO reads “%RH.”

A

AC Power	17
Analog Output, Setup	38, 139
Analyzer, Specifications	55
Auxiliary Input	
Channel 1	65
Configuration	66
Wiring	65

C

Calibration	
Data	45
Procedure	46
Sheet	45
Channel 1	
Auxiliary Input	65, 166
Configuration	66
Components, System	2
Connecting	
Outputs	19
Power	17
Probe Cable	15
RS-485	22
Connections	
Auxiliary Input	65
Connectors, Panel Mount	8
Controls	24
Current Outputs	19

D

Data, Entering	26
DC Power	18
Dewpoint	4
Dimensions	
MDR3 or MDR3-K Probe	6
MDR3-N Probe	6
MR2350 or MR2350-K	7
Panel Mount	8
Wall Mount	7
Display	25
Error Code	50
Oscilloscope	53
Display Only Cells	27

E

Environmental Compliance	x
Error Codes	50
Description	51
Display	50

F

Function	
Families	28
Guide	28

I

Inputs	
Active 4-20mA	21
Auxiliary	20
Loop-Powered 4-20mA	20, 121
Invalid Loop Current	49

L

LCD Display	25
Locking the Matrix	31, 148
Loop Current, Invalid	49

M

Matrix	
Accessing	28
Field Details	32
Locking	31, 148
Moving Through	26
Programming	26, 129
Unlocking	31
Value Descriptions	30
MDR3 Probe	
Dimensions	6
Wiring	13
MDR3-K Probe	
Dimensions	6
MDR3-N Probe	
Dimensions	6
MDR3-N(-K) Specifications	61
MR2350	
Description	1
Dimensions	7
Options	1
Wiring	13
MR2350/MR2350-K	
Specifications	55
MR2350-K	
Description	1
Dimensions	7
Options	1

O

Operation	23
Cells	32
Theory of	4
Outputs	
Analog	38
Connecting	19
Current	19
Voltage	20

P

Panel Mount	2
Connectors.....	8
Dimensions	8
Mounting	13
Specifications	58
Power	
AC Wiring Diagram	17
Applying	23
Connecting	17
DC Wiring Diagram	18
Probe	
Mounting.....	9
Mounting Hardware	10
Replacement	54
Serial Number	45
Specifications	59, 161
Wiring Diagram.....	16
Problems	49
Correcting	52
Situations.....	51
Programming.....	23
Matrix	26, 129
Pushbuttons	24

R

Relays	
Contact Operation	43
Settings	43
Setup	40, 141
Wiring	19
Response Time, Slow	50
RS-485	
Components Required.....	22
Connecting	22

S

Safety	
Auxiliary Equipment	ix
General Issues	ix
Personal Equipment.	x
Setup	
Analog Output	38, 139
Relays	40, 141
Signal Test	53
Specifications	
MDR3 Probe	59
MDR3-N(-K) Probe	61
MR2350/MR2350-K Analyzer	55
Panel Mount Enclosure	58
Standard Configuration	23, 124

U

Unlocking the Matrix	31
--------------------------------	----

V

Voltage, Outputs	20
----------------------------	----

W

Wall Mount	2
Dimensions	7
Mounting	12
Opening the Enclosure	11
Wiring	
Active 4-20mA	21
Auxiliary Input	65
Connections	14
DC Power	18
Diagram	14
Loop-Powered Input	21
MDR3 Probe	13
MR2350	13
Probe Cable	15
Relays	19
Voltage Outputs	20

Warranty

Each instrument manufactured by GE is warranted to be free from defects in material and workmanship. Liability under this warranty is limited to restoring the instrument to normal operation or replacing the instrument, at the sole discretion of GE. Fuses and batteries are specifically excluded from any liability. This warranty is effective from the date of delivery to the original purchaser. If GE determines that the equipment was defective, the warranty period is:

- one year for general electronic failures of the instrument
- one year for mechanical failures of the sensor

If GE determines that the equipment was damaged by misuse, improper installation, the use of unauthorized replacement parts, or operating conditions outside the guidelines specified by GE, the repairs are not covered under this warranty.

The warranties set forth herein are exclusive and are in lieu of all other warranties whether statutory, express or implied (including warranties or merchantability and fitness for a particular purpose, and warranties arising from course of dealing or usage or trade).

Return Policy

If a GE instrument malfunctions within the warranty period, the following procedure must be completed:

1. Notify GE, giving full details of the problem, and provide the model number and serial number of the instrument. If the nature of the problem indicates the need for factory service, GE will issue a RETURN AUTHORIZATION number (RA), and shipping instructions for the return of the instrument to a service center will be provided.
2. If GE instructs the sending of an instrument to a service center, it must be shipped prepaid to the authorized repair station indicated in the shipping instructions.
3. Upon receipt, GE will evaluate the instrument to determine the cause of the malfunction.

Then, one of the following courses of action will then be taken:

- If the damage is covered under the terms of the warranty, the instrument will be repaired at no cost to the owner and returned.
- If GE determines that the damage is not covered under the terms of the warranty, or if the warranty has expired, an estimate for the cost of the repairs at standard rates will be provided. Upon receipt of the owner's approval to proceed, the instrument will be repaired and returned.

We,

GE Sensing
1100 Technology Park Drive
Billerica, MA 01821
USA

declare under our sole responsibility that the

RH-Plus MR2350 Relative Humidity Analyzer with MDR3 Probe
DewPro[®] MMY2650 Trace Moisture Analyzer with DY55 Probe

to which this declaration relates, are in conformity with the following standards:

- EN 61326-1: 2006, Class A, Table 2, Industrial Locations
- EN 61326-2-3: 2006
- EN 61010-1: 2001

following the provisions of the 2004/108/EC EMC and 2006/95/EC Low Voltage Directives.

The unit listed above and any ancillary equipment supplied with them do not bear CE marking for the Pressure Equipment Directive, as they are supplied in accordance with Article 3, Section 3 (sound engineering practices and codes of good workmanship) of the Pressure Equipment Directive 97/23/EC for DN<25.

Billerica - August 2010

Issued



Mr. Gary Kozinski
Certification & Standards, Lead Engineer



Customer Support Centers

U.S.A.

The Boston Center
1100 Technology Park Drive
Billerica, MA 01821

U.S.A.

Tel: 800 833 9438 (toll-free)

978 437 1000

E-mail: sensing@ge.com

Ireland

Sensing House
Shannon Free Zone East
Shannon, County Clare
Ireland

Tel: +353 (0)61 470291

E-mail: gesensingsnnservices@ge.com

An ISO 9001:2000 Certified Company

www.gesensinginspection.com/en/about_us/quality.html

www.gesensinginspection.com

©2010 General Electric Company. All rights reserved.
Technical content subject to change without notice.

63005129 Rev. F

